

Hybrid Numerical Techniques for Power Transformer Modeling: A comparative analysis validated by measurements

M. Tsili¹, A. Kladas¹, P. Georgilakis², A. Souflaris², C. Pitsilis², J. Bakopoulos², D. Paparigas²

¹Electric Power Division,
Department of Electrical & Computer Engineering
National Technical University of Athens
9, Iroon Polytechniou Street, 15780 Athens, Greece
e-mail: kladasel@central.ntua.gr

²Schneider Electric S.A.,
Elvim Plant
32011 Inofyta Viotia, Greece

Abstract— Power transformer analysis and design focussing on the equivalent circuit parameter evaluation by magnetic field numerical calculation is presented. The proposed method adopts a particular reduced scalar potential formulation enabling 3D magnetostatic problem solution. This method, necessitating no source field calculation, in conjunction with a mixed finite element –boundary element technique, results in a very efficient 3D numerical model for power transformer design office use. Computed results are validated through measurements. Such a methodology is very promising for investigation concerning losses and short circuit voltage variations with the main geometrical parameters.

MODELING TECHNIQUES

Numerical modeling techniques are now-a-days well established for power transformer analysis and enable representation of all important features of these devices [1,2]. More particularly, techniques based on finite elements present interesting advantages for nonlinear characteristics simulation. The leakage inductance evaluation has been extensively analyzed [10], as well as eddy current loss in transformer tank walls [7,8], iron lamination characteristics and design considerations [9]. Moreover, the combination of boundary and finite elements is widely used for electromagnetic problems since the electromagnetic field is not only confined to the conductors but it expands over extensive parts of air, where the use of a boundary element representation can significantly decrease the computational effort [5,6].

In the present paper a particular scalar potential formulation has been developed, enabling the 3D magnetostatic field analysis. According to our method the magnetic field strength \mathbf{H} is conveniently partitioned to a rotational and an irrotational part as follows [3]:

$$\mathbf{H} = \mathbf{K} - \nabla\Phi \quad (1)$$

where Φ is a scalar potential extended all over the solution domain while \mathbf{K} is a vector quantity (fictitious field distribution), defined in a simply connected subdomain comprising the conductor, that satisfies Ampere's law and is perpendicular on the subdomain boundary.

The boundary element method is derived through discretization of an integral equation that is mathematically equivalent to the original partial differential equation. The boundary integral equation corresponding to Laplace equation is of the form:

$$c(s)\Phi(s) + \oint_{\Gamma} \left[\Phi(s') \frac{\partial G(s', s)}{\partial n} - G(s', s) \frac{\partial \Phi(s')}{\partial n'} \right] ds' = 0 \quad (2)$$

where s is the observation point, s' is the boundary Γ coordinate, n' is the unit normal and G the fundamental solution of Laplace equation in free space. Therefore, the matrix form of the equations corresponding to a coupled finite element/boundary element solution domain is of the form [5,6]:

	1 . . . r	r+1 . . . m	m+1 . . . N _k	N _k +1 . . . N	N+1 . . . N+k	N+k+1 . . . N+n-k	N+n-k+1 . . . N+n			
1 ⋮ r	S_{ij}								Φ ₁ ⋮ Φ _r	F
r+1 ⋮ m					T_{ij}				Φ _{r+1} ⋮ Φ _m	
m+1 ⋮ N _k									Φ _{m+1} ⋮ Φ _{N_k}	=
N _k +1 ⋮ N									Φ _{N_k+1} ⋮ Φ _N	
N+1 ⋮ N+k					H_{ij}		-G_{ij}		0Φ _{r+1} ⋮ 0Φ _m 0Φ _{N_k}	O
N+k+1 ⋮ N+n-k									0Φ _{m+1} ⋮ 0Φ _{N_k}	
N+n-k+1 ⋮ N+n									0Φ _{N_k+1} ⋮ 0Φ _N 0Φ _N	

where $[S]$ and $[F]$ are the FEM matrices, $[H]$ and $[G]$ the BEM matrices while T_{ij} are the terms used to link the FEM to the BEM region.

RESULTS AND DISCUSSION

The proposed reduced scalar potential formulation has been applied in the 3D numerical analysis of a transformer under short circuit for its leakage reactance calculation. The case of the one phase part of a 1000 kVA, two tap 20-15kV / 400V

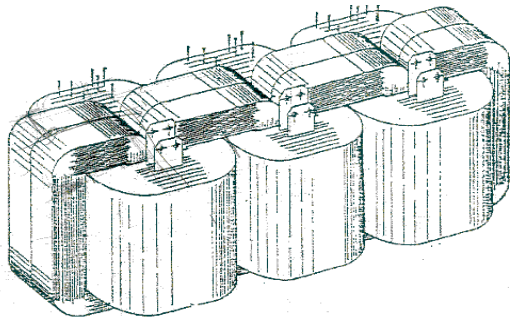

Fig. 1. Active part configuration of the three phase shell type distribution transformer considered.

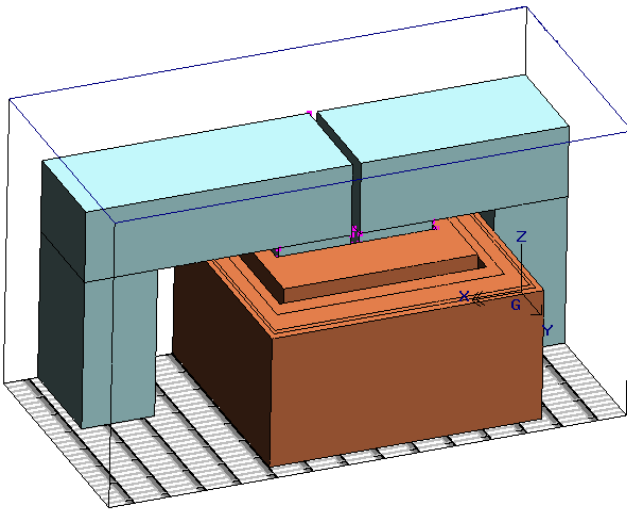

Fig. 2. Perspective view of the one phase transformer part modelled.

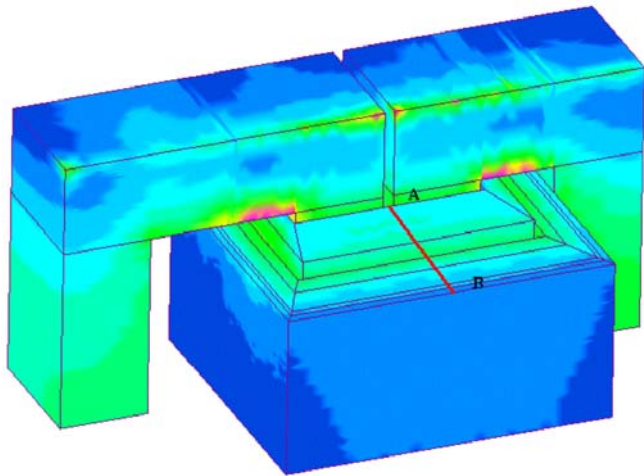

Fig. 3. Magnetic flux density magnitude distribution during short-circuit test

three phase shell type power transformer, shown in Fig. 1, has been considered. Fig. 2 illustrates the perspective view of the one-phase transformer part modelled.

The field values computed by the proposed 3D formulation have been compared to those measured by a Hall effect probe during short-circuit test. Fig. 4 gives the variation of the perpendicular flux density component B_n along the line AB,

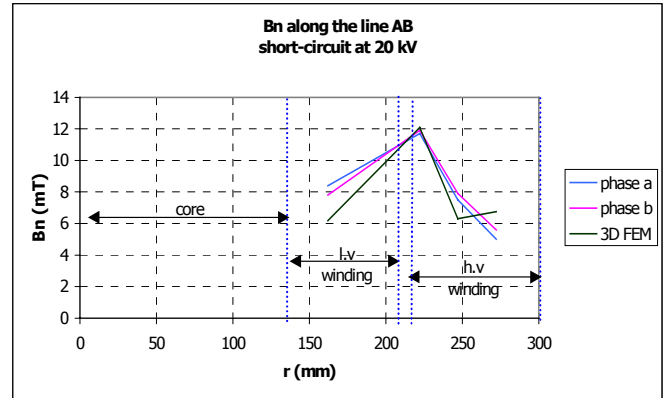

Fig.4. Comparison of measured and computed field values along the line AB.

positioned as shown in Fig. 2, in case of short-circuit with the high voltage winding connections corresponding to 20 kV voltage supply. This figure illustrates the good correlation of the simulated results with the local leakage field measurements.

REFERENCES

- [1] P. Georgilakis, N. Hatzigiorgiou, D. Pappas, "AI Helps Reduce Transformer Iron Losses", *IEEE Computer Applications in Power*, Vol. 12, Nr. 4, 1999, pp. 41-46.
- [2] P.S. Georgilakis, N.D. Doulamis, A.D. Doulamis, N.D. Hatzigiorgiou, S.D. Kollias, "A Novel Iron Loss Reduction Technique for Distribution Transformers Based on a Combined Genetic Algorithm - Neural Network Approach", *IEEE Trans. on Systems, Man, and Cybernetics, Part C, Applications and Reviews*, Vol. 31, Nr. 1, Feb. 2001, pp. 16-34.
- [3] A.G. Kladas, M.P. Papadopoulos, J.A. Tegopoulos, "Leakage Flux and Force Calculation on Power Transformer Windings under short-circuit: 2D and 3D Models Based on the Theory of Images and the Finite Element Method Compared to Measurements", *IEEE Trans. on Magnetics*, Vol. 30, Nr. 5/2, Sept. 1994, pp. 3487-3490.
- [4] Z.X. Feng, "The treatment of singularities in calculation of magnetic field by using integral method", *IEEE Trans. on Magnetics*, Vol. 21, Nr. 6, Nov. 1985, pp. 2207-2210.
- [5] G. Meunier, J.L. Coulomb, S.J. Salon, L. Krahenbul, "Hybrid Finite Element Boundary Element Solutions for three dimensional scalar potential problems", *IEEE Trans. on Magnetics*, Vol. 22, Nr. 5, Sept. 1986, pp. 1040-1042.
- [6] S.J. Salon, J. D'Angelo, "Applications of the hybrid finite element - boundary element method in electromagnetics", *IEEE Trans. on Magnetics*, Vol. 24, Nr. 1, Jan. 1988, pp. 80-85.
- [7] A. J. Moses, "Comparison of transformer loss prediction from computed and measured flux density distribution", *IEEE Trans. on Magnetics*, Vol. 34, Nr. 4, 1998, pp. 1186-1188.
- [8] C. Lin, C. Xiang, Z. Yanlu, C. Zhingwang, Z. Guoqiang, Z. Yinhan, "Losses calculation in transformer tie plate using the finite element method", *IEEE Trans. on Magnetics*, Vol. 34, Nr. 5, 1998, pp. 3644-3647.
- [9] I.L. Nahas, B. Szabados, R.D. Findlay, M. Poloujadoff, S. Lee, P. Burke, D. Perco "Three dimensional flux calculation on a three-phase transformer", *IEEE Trans. on Power Delivery*, Vol. 1, Nr. 3, 1986, pp. 156-160.
- [10] K. Zakrzewski, B. Tomczuk, "Magnetic field analysis and leakage inductance calculation in current transformer by means of 3D integral method", *IEEE Trans. on Magnetics*, Vol. 32, Nr. 3, 1996, pp. 1637-1640.