

Accurate orientation of the gyroscope's calibration system

Evangelia LAMBROU, George PANTAZIS, Greece

Key words: orientation, astronomical azimuth, gyroscope, collimator, accuracy

SUMMARY

Gyroscopes and gyrotheodolites need to be calibrated in arranged time period for their proper function. As known these instruments measure horizontal angles from the astronomical North (astronomical Azimuth) with an accuracy of $\pm 3''$.

This calibration is done with a collimator system, which is a level telescope set to the infinity. As an instrument is placed in front of the collimator's telescope, its cross-hairs are aligned with the cross-hairs of the collimator and the instrument measures the astronomical azimuth of the direction between the point where it is forced centered and the point where the collimator's cross-hairs coincide.

This work presents a method for the accurate determination of the astronomical azimuth of a given direction. The theoretical analysis, of a new method, which leads, to the determination of the astronomical azimuth, in short time (about 20min) is described. The achieved accuracy is also given.

This determination may be done by astrogeodetic observations to the Polaris (α Ursa Minoris) by using a new-constructed system consisting of a high accuracy total station connected with a GPS receiver, which provides accurate UTC time.

The astronomical azimuth will be transferred accurately to the demanded direction at the collimator system at the time of its installation by an autocollimation procedure using convenient equipment.

An application of the methodology at a specific collimator is presented accompanied by the results and the achieved accuracy.

1. INTRODUCTION

The gyroscope theodolite or gyrotheodolite has a built-in free swing and fast rotation gyroscope that vacillates automatically provides the direction of the Astronomical true North by an accuracy of $\pm 3''$.

The gyroscope theodolite has the following advantages:

- Determines the astronomical azimuth with high accuracy for common geodetic field works.
- Its operation is independent from the sight and light conditions.
- The build-in gyroscope attachment doesn't prevent other measurements by the theodolite.

Gyroscope theodolites today are used for:

- The initial orientation of the 3D – geodetic networks
- Underground surveying works in caves and mines.
- Orientation of airport radar or satellite antennas.
- Ship navigation
- Orientation of army systems

The gyroscope theodolites used to be calibrated before and after their use in an arranged time period frame for their proper function. This is a very important check, which ought to be done carefully and repeatedly, in order to assure the proper function of the instrument and the

correct value of the measured astronomical azimuth. This certification is done by using a collimator, which is a system for checking the theodolites.

2. COLLIMATOR

A collimator is a telescope focused to infinity, the reticule of which is illuminated. The rays of light emanating from the reticule will be parallel when they leave the objective lens. If another telescope focused to infinity is pointed at the collimator, the cross-hairs of that collimator will be seen as a perfect target at infinity.

If the line of sight of the telescope is parallel to the line of collimation of the collimator, the cross-hairs of the telescope will be seen to coincide with those of the collimator's, irrespective of whether there is any small displacement up or down, right or left, between the two objectives. As parallel rays are involved, the distance of the objective is of no importance, the telescope can be directly in front of the collimator (fig. 1).

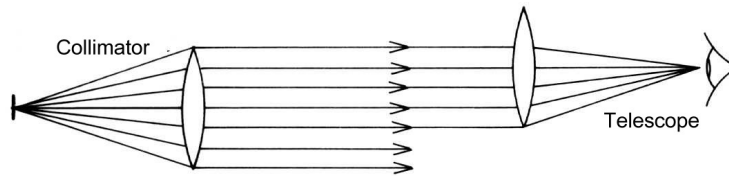

Figure 1: Sighting with a telescope into a collimator.

Collimators are usually permanently mounted on accurately levelled pillars in laboratories where they are used as references and to which theodolites and levels are checked and adjusted.

Collimators and the autocollimation process are also used for:

- Measuring small angles, angular changes and deflections
- Establishing and checking perpendicular directions
- Calibrating angle measuring devices
- Determining the accurate initial reference direction when measuring angles with high accuracy.

3. ASTRONOMICAL ORIENTATION OF THE COLLIMATOR

As *Astronomical azimuth* A_{AB} of a direction AB is the angle between the two vertical planes, which include the vertical of point A (fig. 2). The first plane is parallel to the earth's

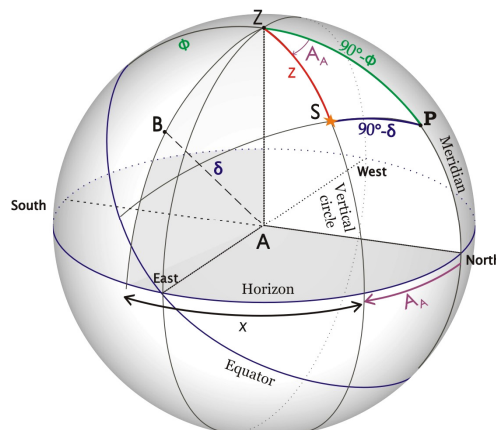

Figure 2: Astronomical azimuth

rotation axis and the second includes the point B. In other words it is the angle between the astronomical meridian plane of point A and the vertical plane of point B. It is measured from the north side of the meridian clockwise from 0° to 360° (Balodimos, 2002).

The determination of the astronomical azimuth of the collimator's line of sight refers to the determination of the astronomical azimuth of the direction OS, where O is the point of the instrument station and S is the point where the instrument is forced centred in front of the collimator's telescope (fig. 3). The horizontal angle b between the direction SO and the collimator's axis SC can be measured.

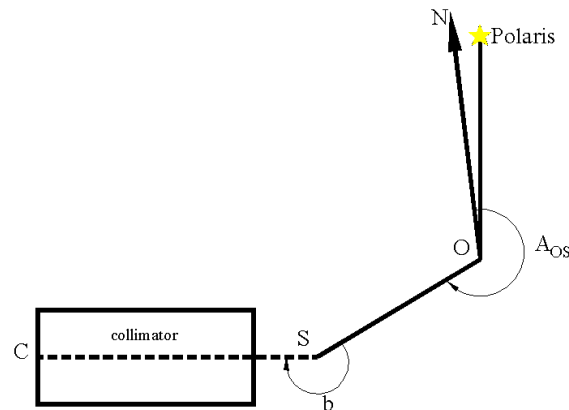

Figure 3: The elements for the determination of the collimator's axis astronomical azimuth

The astronomical azimuth A_{SC} of the direction SC will be equal to

$$A_{SC} = A_{OS} + b + 180^\circ - 360^\circ \quad (1)$$

3.1 Determination of astronomical azimuth

The determination of the astronomical azimuth of a direction refers to the determination of the direction of the meridian of the station point, which isn't realized on site. This can be done as follows:

i) *Azimuth by equal altitudes of a star.* To define the meridian we have to determine the direction of the celestial pole. A simple method is probably that of observing a star at equal altitudes before and after its culmination. The meridian direction is defined by bisecting the horizontal angle between the two observed positions of the star. The accuracy of the method is about $\pm 7'$, but if one completes a 6 to 8 hours observation he may reach $\pm 1''$ (Mackie, 1971).

ii) *Azimuth by observing a circumpolar star near elongation.* By this method the meridian direction is defined, by observing a star at the time of its elongation (when the angle between the plane of the meridian and the vertical circle of the star is maximum). The accuracy of the method is about $\pm 3''$ (Mackie, 1971).

The astronomical azimuth of a direction can also be determined by measuring the angle between the vertical circle of the station point (S) and the vertical circle of a celestial body, at a specific time and the azimuth of the celestial body will be determined at the same time. The most accurate methods for this definition are:

iii) Ex-meridian observations to stars or the Sun, in which altitudes are measured. By this method the altitude of the celestial body is measured at an ordinary place. The method requires the knowledge of both the value of the astronomical latitude and the correction of the angle caused by the astronomical refraction.

The influence of the above two parameters can be eliminated by the observations of two stars at specific relative positions $z_1 = z_2$ and $A_1 = 360^\circ - A_2$. In this case the accuracy of the method is about $\pm 10''$. If the Sun has been observed the accuracy is about $\pm 15''$ (Mackie, 1971).

iv) Observing a close circumpolar star at any hour angle. By this method the UTC time of each observation is measured. Then the hour angle of the star is computed by the equation (Mueller, 1969):

$$h = \theta + \Lambda - \alpha \quad (2)$$

as the Greenwich sidereal time θ can be calculated by

$$\theta = \theta^{0hUT} + (UTC + DUT) \cdot f \quad (3)$$

where

θ^{0hUT} = The Greenwich sidereal time at 0^hUT.

DUT = The correction at the Coordinated Universal Time

f = The ratio of the duration of the mean solar day to the mean sidereal day
= 1.00273790935

α = the right ascension of the star.

Λ = The astronomical longitude of the station point.

The astronomical azimuth A_s is calculated by the formula:

$$\tan A_s = \frac{-\sinh}{\cos \Phi \cdot \tan \delta - \sin \Phi \cdot \cosh} \quad (4)$$

which is derived from the basic laws of spherical trigonometry applied to the astronomic triangle.

Where

Φ = The astronomical latitude of the station point, δ = the declination of the star

The accuracy of this method is about $\pm 1''$.

This is the most accurate of all methods. In the North hemisphere for latitudes 5° to 60° , the most convenient star is the **α Ursa Minoris** or Polaris, which has the following advantages:

- Lies in an easily recognizable constellation.
- Being a star of magnitude 2.1
- Its distance from the North celestial Pole is about $45'$ so its astronomical azimuth at any time fluctuates from 359° to 1° .
- The sighting of the Polaris is very easy as it moves very slowly.

In the South hemisphere a correspondent star is **σ Octantis**. **σ Octantis** is located about $45'$ from the South Celestial Pole and has a magnitude of 5.5. It's difficult to recognize it on the celestial sphere and for this reason it is necessary to know before hand the approximate azimuth of the reference meridian.

3.2 The system for the determination of astronomical azimuth.

The above mentioned accuracy and the necessary observations are obtained through a system consisting of a high – accuracy digital total station (TDM 5000 – Leica) and a GPS receiver (4000 DL – Trimble) (fig. 4) (Lambrou, 2003).

The digital total station offers the possibility of automatic registration of horizontal and vertical angles, to an accuracy of $1''$ or $0''.3$ (Leica, 1997), after a suitable trigger by the observer, up to a rate of 30 observations per minute.

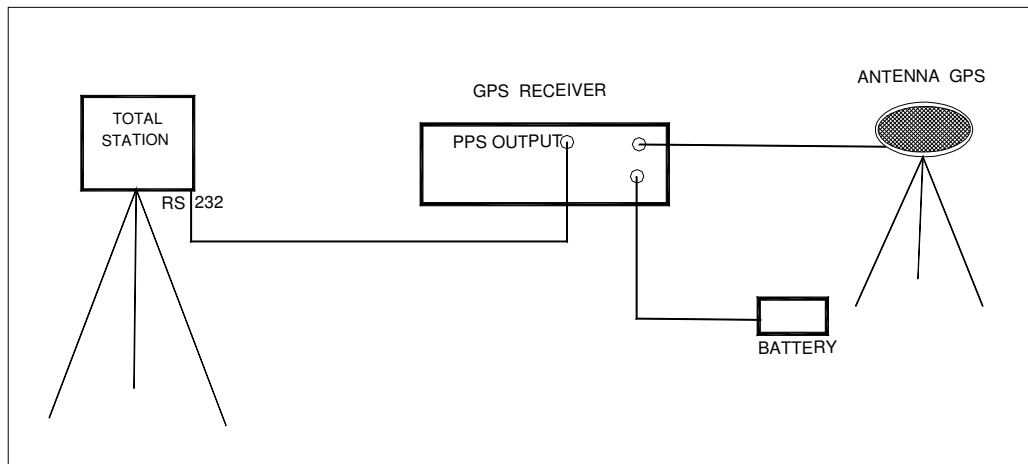

Figure 4: System for astronomical observations

It can also register the time of its observation (using an internal clock) to an accuracy of 1msec. In addition, it constantly checks the levelling of itself and automatically makes appropriate corrections to the measured angles when necessary (Leica, 1997). It's obvious that all random readings and registering errors are avoided.

The GPS receiver provides accurate time information in the form of 1pps (pulse per second) output, which is synchronised with the UTC time to an accuracy of a few microseconds (Trimble, 1990). Of course it can also provides the geodetic coordinates of the observing station, which may serve as approximate values of the astronomical coordinates of the station. The timing pulse of the GPS is fed to the total station, through a suitable cable and converter, and is used by the loaded software to the total station, for the registration of the UTC time to an accuracy of 1msec (Lambrou, 2003).

3.3 Error analysis.

The accuracy of the determination of the astronomical azimuth σ_A of the collimator's axis is analyzed as follows:

- i. The internal uncertainty of the determination of the astronomical azimuth σ_{A_s} of the star, about $\pm 0''.3$, depends on:
 - The sighting error σ_s , which is random and is reduced through the number of sightings.
 - The total uncertainty of the hour angle method, by using the previously described system is derived at, after data calculation.
- ii. To the above uncertainty all the following external errors must be added:
 - The error from the celestial coordinates (α , δ) of Polaris that is $\sigma_\alpha = \pm 0''.015$ and $\sigma_\delta = \pm 0''.01$ as the astronomical ephemeris provides them (Marriot, 2004).
 - The error σ_{A_ϕ} from the estimate value of the astronomical latitude that is used in the formula. The influence of this error depends mainly on the altitude at which the Polaris is observed. Figure 5 presents the error from this source, when the observation place is at the latitude of 20° to 60° and the error δ_ϕ in the estimation of the astronomical latitude value is from $\pm 5''$ to $\pm 30''$.

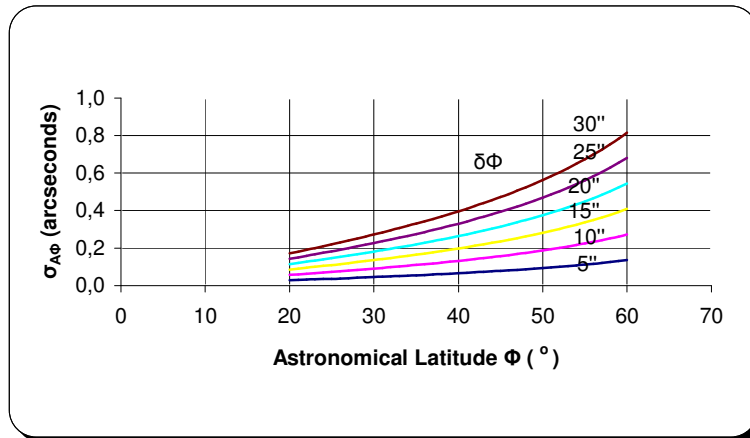

Figure 5: Diagram of the error σ_{A_Φ} relative to the estimation of the value of Φ (δ_Φ) and the astronomical latitude of the observation place Φ .

- The error σ_{A_Λ} from the use of an estimate value of astronomical longitude which is almost insignificant. Figure 6 presents this error relative to the astronomical latitude Φ of the observation place and the error δ_Λ in the longitude value estimation.

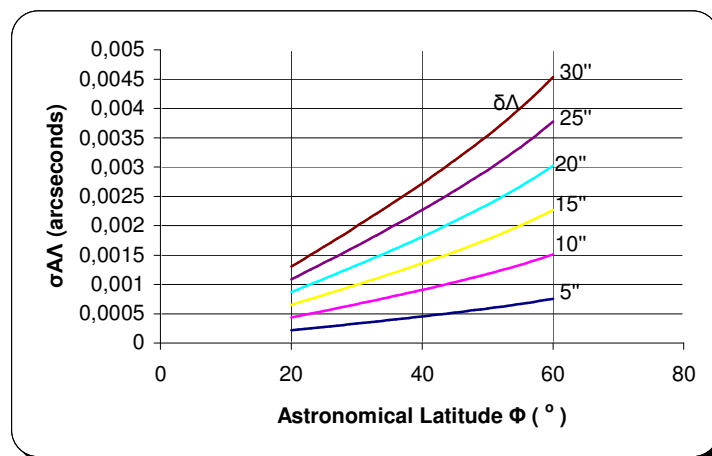

Figure 6: Diagram of the error σ_{A_Λ} relative to the estimation of the value of Λ (δ_Λ) and the astronomical latitude of the observation place Φ .

- Errors of the total station right position (leveling), which in this system are automatically corrected.
- The uncertainty σ_e of the sighting of the initial direction which depends on the kind of target and its distance from the instrument station as well as at the observer's sighting skill. This error, by using special targets and repeatable measurements, may reach $\pm 1''$.
- The error σ_b in the measurement of the horizontal angle b between the collimator's axis and the initial direction is about $\pm 1''$.

The total error in the determination of the astronomical azimuth of the collimator's axis is calculated by the covariance law as follows:

$$\sigma_A = \pm \sqrt{\sigma_{A_s}^2 + \sigma_{A_\phi}^2 + \sigma_{A_\lambda}^2 + \sigma_e^2 + \sigma_b^2} \quad (5)$$

An estimation of the total error is about $\pm 1.5''$.

4. APPLICATION

The previous analyzed methodology was applied in a laboratory, which had the responsibility to check and adjust some gyrotheodolites for the Greek army. The collimator had been installed at a properly designed place, on a special pillar, which insured the permanence and stability of its position (fot.1)



Fot 1 : Placing of the collimator.

The measuring system was put initially at point A, while at point B (fig. 7) a fixed tribrach was established, which insured the unique centering of the instruments or the targets without uncertainties. At the beginning, at point B a special target set, of a bronze cone, (fot.2) was placed in order to insure high pointing accuracy.

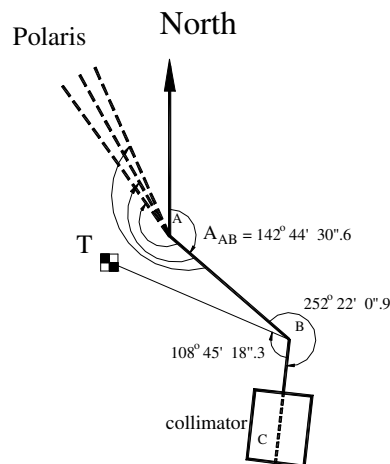
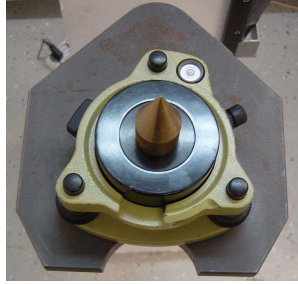

Figure 7: Formation arrangement measurements.



Fot 2: System for high sighting accuracy.

Thirty four sightings were carried out to Polaris within 20 minutes. At every sighting the following were registered:

- The Coordinate Universal Time UTC
- The horizontal angle between the initial zero reference direction AB and the position of the Polaris, for each measurement.

The geodetic coordinates φ , λ of the point A were determined using the GPS System.

The celestial coordinates α , δ of Polaris for the time of the observations were determined using astronomical ephemeris by interpolation.

The above data proceedings determined the value of the astronomical azimuth of the direction AB equal to **142° 44' 30".6**.

The accuracy of this value was calculated by the accuracy of the astronomical observations which was about $\pm 0".4$ and the accuracy of the sighting, the cone target on point B which was about $\pm 0".4$ after sighting measurements in four periods.

The angle between the direction BC of the collimator axis and the direction BA (fig.7) was measured by the alternation between the total station and the bronze cone target on the fixed tribraches. The angle ABC was measured in four periods. The determined angle value is **252° 22' 0".9** with an accuracy of $\pm 0".4$.

The final derived value of the astronomical azimuth of the collimator's axis is calculated by the equation:

$$A_{BC} = A_{AB} + ABC + 180^\circ - 360^\circ = \mathbf{215^\circ 6' 31".5}$$

The total error of the determination is **$\pm 0".7$**

Additionally, for the fast check - up of any probable displacement of the collimator's place, caused by any reason, the value of an angle is determined. This angle formed between the direction of the collimator's axis BC and another direction BT marked by a special target on a building at a distance of about 200m (fig.7).

The value of the angle CBT was **108° 45' 18".3 \pm 1"**

5. CONCLUSIONS

- The determination of the astronomical azimuth of a collimator's axis or any other arbitrary direction may be done by an accuracy of about **$\pm 1"$** by using the above described system, the total station and the GPS receiver, by the hour angle method and by sightings to Polaris.
- Special attention is needed to the marking of any points, which determine the directions, and also attention is needed to the measurement of the corresponding angles.
- The total duration of the application of the above methodology is about 1 hour.

- This methodology appears as convenient, fast, accurate and low cost, as the accurate periodical check of the gyroscope thodolite is necessary.

REFERENCES

1. Balodimos D.- D, Stathas D., 2002, Geodetic instrumentation and, angles and distances measuring methods, NTUA, School of Rural and Surveying Engineering (In Greek), Athens.
2. Lambrou E., 2003, Development of a methodology for Astrogeodetic determinations using Digital Geodetic Instruments, PhD Thesis (in Greek), National Technical University of Athens, Department of Rural and Surveying Engineers
3. Leica Heerbrugg AG, 1997, Users manual for TM 5000/ TDM 5000 system, V2.2, Switzerland
4. Mackie J. B., 1971, The elements of Astronomy for Surveyors, Seventh edition, Charles Griffin & Company Ltd, London.
5. Marriot C., 1992-2004, Skymap Pro Version 10, Thompson Partnership, U.K.
6. Mueller I., 1969, Spherical and practical Astronomy as applied to Geodesy, Frederick Ungar Publishing Co, Inc.
7. Trimble Navigation, 1990, Operation Manual for model 4000DL, Revision A, Sunnyvale, California, U.S.A

BIOGRAPHICAL NOTES

Surname : LAMBROU
First name : EVANGELIA
Date of birth : 16 November 1965
Place of birth : Piraeus

- 1983 Graduated from the 2nd high school of Piraeus.
- 1984 – 1990 Attended and graduated from the Rural & Surveying Engineering School of the National Technical University in Athens. Mark 7.24 (max 10)
- 1992 Postgraduate scholar in the section of Topography of Rural & Surveying Engineering School, National Technical University of Athens.
- 2003 Defended thesis "Development of a methodology for astrogeodetic determinations using Geodetic instruments", in the Rural & Surveying Engineering School, National Technical University of Athens.
- Research interests:
 - GPS
 - Measure and monitoring deformations and displacements of structures and large earth areas
 - Surveying and documenting monuments
 - Investigating the orientation of monuments
 - Determining the astronomical azimuth and coordinates Φ , Λ using digital geodetic instruments.
- Publications and presentations: 10

Surname : PANTAZIS
First name : GEORGE
Date of birth : 29 September 1966
Place of birth : Athens

- ✓ 1984 Graduated from high school of Derveni region – Korinth
- ✓ 1984 – 1990 Attended and graduated from the Rural & Surveying Engineering School of the National Technical University in Athens. Mark 7.51(max 10)
- ✓ 1991 Postgraduate scholar in the section of Topography of Rural & Surveying Engineering School, National Technical University of Athens.
- ✓ 2002 Defended thesis "Investigation of monuments orientation using geodetic and astronomical methods. Application at Meteora", in the Rural & Surveying Engineering School, National Technical University of Athens.
- ✓ Research interests:
 - GPS
 - Measure and monitoring deformations and displacements of structures and large earth areas
 - Surveying and documenting monuments
 - Investigating the orientation of monuments
 - Determining the astronomical azimuth and coordinates Φ , Λ using digital geodetic instruments.
- ✓ Publications and presentations: 10

CONTACTS

Dr Evangelia Lambrou
National Technical University of Athens
School of Rural and Surveying Engineering
Department of Topography, Laboratory of General Geodesy
9 Heron Polytechniou, Zografos, 15780
Athens
GREECE
Tel: 00302107722737
Fax : 00302107722728
Email : litsal@central.ntua.gr

Dr George Pantazis
National Technical University of Athens
School of Rural and Surveying Engineering
Department of Topography, Laboratory of General Geodesy
9 Heron Polytechniou, Zografos, 15780
Athens
GREECE
Tel: 00302107722696
Fax : 00302107722728
Email: gpanta@central.ntua.gr