

WISSENSCHAFTLICHE ARBEITEN
DER FACHRICHTUNG VERMESSUNGSWESEN DER UNIVERSITÄT HANNOVER
ISSN 0174 - 1454

Nr. 217

H. PELZER / R. HEER (Eds.)

Proceedings of the
6th INTERNATIONAL FIG-SYMPIOSIUM
ON
DEFORMATION MEASUREMENTS

24 - 28 February, 1992

HANNOVER 1996

ERRORS IN THE DETERMINATION OF VERTICAL DISPLACEMENTS USING
TRIGONOMETRIC LEVELLING

by

IOANNIS GOUGKOUTOUDIS EVANGELIA LAMEROU GEORGE PANTAZIS

LABORATORY OF GENERAL GEODESY
NATIONAL TECHNICAL UNIVERSITY OF ATHENS
IROON POLYTECHNIU 9
15772 - ZOGRAFOU
ATHENS- GREECE

ABSTRACT

The vertical displacements of control points ,which are inaccessible using the classical method of geometric levelling ,can be determined using the method of Trigonometric Levelling .In this article ,the errors appeared in determining vertical displacements with this method are discussed .Also, special reference is made to the error caused by the change of the refraction coefficient .Using the proposed solution ,the determination of the vertical displacements and the determination of the change of the refraction coefficient can be done simultaneously.

1. DETERMINATION OF VERTICAL DISPLACEMENTS USING TRIGONOMETRIC LEVELLING.

The method of Trigonometric Levelling gives us many possibilities in determining the vertical displacements of control points in constructions, where the use of classical geometric levelling is not possible.

In this method, if the vertical angles (Z), the horizontal distances (D) the vertical position of the instrument (I) Fig. 1. and the refraction coefficient (K) are changed between two epoques of measurements, then the vertical displacement of a control point can be calculated from the equation:

$$\Delta h = D \frac{1 + \tan^2 Z}{\rho} \Delta Z + \tan Z \Delta D - \frac{D^2}{2R} \Delta K + \Delta I \quad (1)$$

where:

D = horizontal distance between instrument point and control point.

Z = vertical angle.

ΔZ = the vertical angle's change.

ΔD = the distance's change.

ΔI = the instrument point's change in vertical position.

ΔK = the refraction coefficient's change.

R = earth's radius.

$\rho = 636620$.

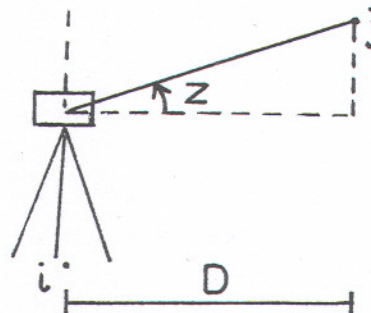

FIGURE 1

The influence of each term in the equation (1) at the value of Δh depends on the duration of work and the kind of displacements.

The duration of the field work can be related to:

- Short-term measurements, during which the instrument point has no displacement.
- Long-term measurements, during which the instrument point has displacement.

In both cases, the control point, may be influenced only by vertical displacements or by both vertical and horizontal displacements. In this article both cases are examined.

2. ERRORS IN THE TRIGONOMETRIC LEVELLING DUE TO THE DURATION OF FIELD WORK AND THE KIND OF DISPLACEMENTS.

2.1 First case : The observation are sort-term while the control points have only vertical displacements.

In this case the accuracy of the vertical displacements' determination is influenced, by the error in the vertical angle's measurement, the error in the change of the refraction coefficient's value and the error in the distance's measurement to the control points.

In Fig. 2. we can see the mean square error in the determination of vertical displacements when measuring distances and vertical angles in two or three periods .

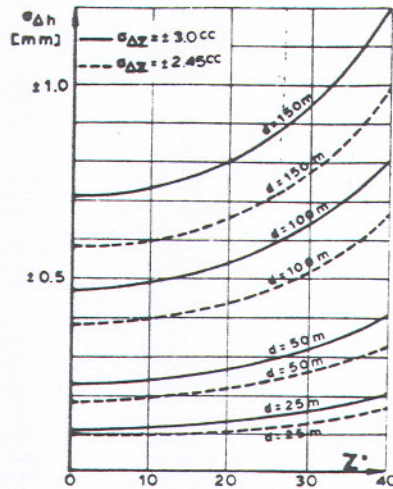

FIGURE 2 :Mean square error of vertical displacements' determination caused by the error in measurement of the vertical angle.

Combining both the influence of the vertical angle's measurement error and the refraction coefficient's determination error ,we can compute the mean square errors in determining the vertical displacements. In Fig. 3. we can see the changes in the mean square errors of the vertical displacements' determination when the measurements have been taken from only one standing point.

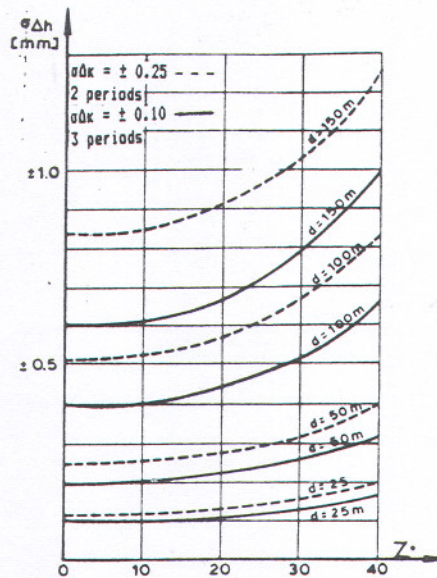

FIGURE 3 :Change in the mean square errors of the vertical displacements' determination for the first case.

2.2 Second case: The observations are long-term, while the control points are influenced only by vertical displacements.

In this case all the terms of equation (1) influence the accuracy of the vertical displacements' determination.

The instrument's vertical position change (ΔI) between two epochs of measurements, can be determined from the vertical angles' measurement towards four or more reference points.

$$\Delta I = - \frac{D}{\rho_{cc}} (1 + \tan^2 Z) \Delta Z \quad (2)$$

(D, z from instrument point to the reference points).

If $Z=0$ then:

$$\Delta I = - \frac{D}{\rho_{cc}} \Delta Z \quad (3)$$

The error $\sigma \Delta I$ can be calculated from the distance D and the number of reference points (n_i) according the equation:

$$\sigma \Delta I = \sigma \Delta h = \frac{D}{\rho_{cc} \sqrt{n_i}} \sigma \Delta Z \quad (4)$$

In Fig.4. we can see the dependence of $\sigma \Delta h$ from D and n_i , if $\sigma \Delta Z = \pm 3.00$

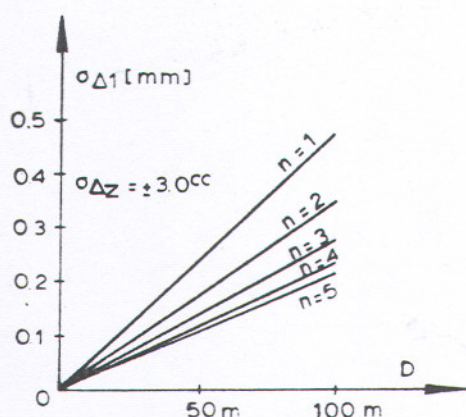

FIGURE 4: Dependence of the $\sigma \Delta h$ error from the distance measurement and the number of the reference points.

Combining all the corrections mentioned above we can draw the curves showing the mean square errors of the vertical displacements' determination which appear in Fig.5.

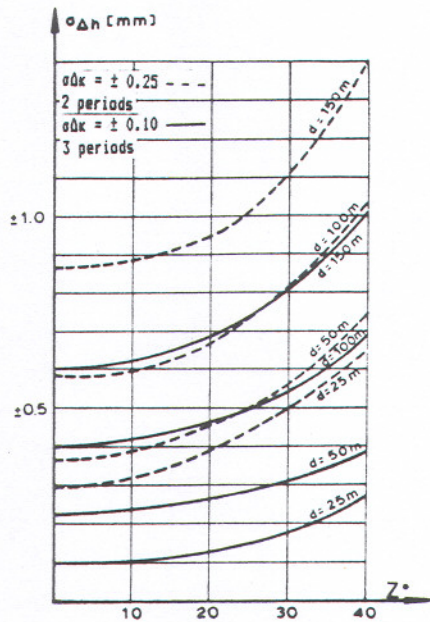

FIGURE 5 : Mean square errors of the vertical displacements' determination for the second case.

2.3 Third case: The observations are short-term while the control points have vertical and horizontal displacements .

The accuracy in determining vertical displacements in this case will be influenced by the first case's errors plus the error in the determination of the change in distances between the instrument point and control points. The horizontal points' displacements are easily determined by intersections Fig. 6.

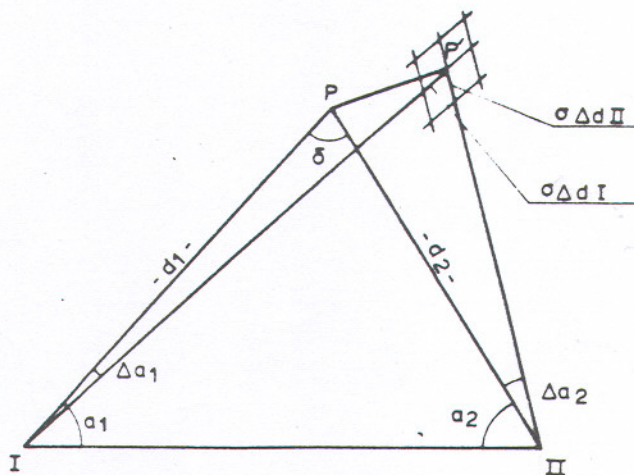

FIGURE 6 : Errors due to the change in distances.

The errors due to the change in distance will be:

$$\sigma_{\Delta d I} = \frac{\sigma_{\Delta \alpha}}{\rho^{\text{cc}} \sin \delta} d_2 \quad (5)$$

$$\sigma_{\Delta d II} = \frac{\sigma_{\Delta \alpha}}{\rho^{\text{cc}} \sin \delta} d_1 \quad (6)$$

From the above equations, if $d_1 = d_2 = D$ the error in the vertical displacement's determination is:

$$\sigma_{\Delta h} = \frac{\sigma_{\Delta \alpha}}{\rho^{\text{cc}} \sin \delta} D \tan Z \quad (7)$$

The error $\sigma_{\Delta \alpha}$ in equation (7), which is the error in the angle's change will depend on:

-The error in the directions' measurement at the primitive and the current period of the observations.

-The error of the deflection of the preeminent axis of theodolite.

The influence of the horizontal displacement's error in determining accurately the vertical displacements is about 15% smaller, using multiple intersection from three points than when using a single intersection. In Fig.7. we can see the curves showing the mean square errors, for this case.

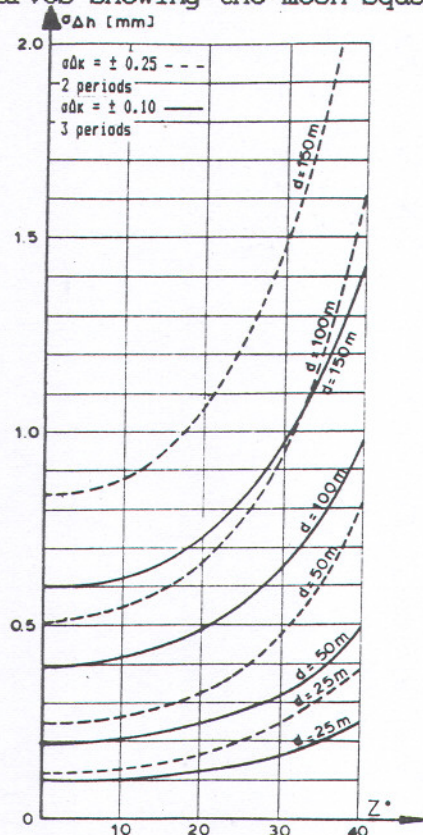

FIGURE 7 : Mean square errors of the third case.

2.4 Fourth case : The observations are long-term while the control points have vertical and horizontal displacements .

The accuracy in determining vertical displacements depends on all the previously mentioned errors, such as:

- Vertical angle measurement's error.
- The refraction coefficient change determination's error.
- Distance determination's error.
- The error in determining the change of the vertical position of the instrument point.

The curves showing the value of the mean square errors of the vertical displacements' determination that concern the fourth case ,appear in the diagram of Fig. 8.

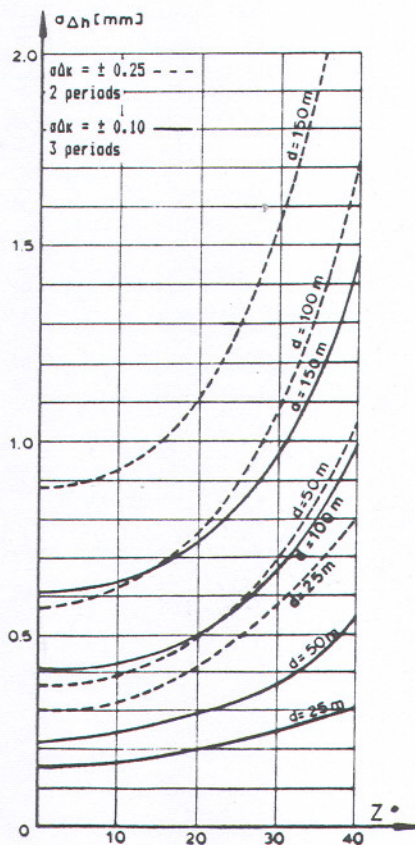

FIGURE 8 : Mean square errors of the vertical displacements' determination for the fourth case.

3. INFLUENCE OF THE CHANGE IN THE REFRACTION COEFFICIENT IN THE CALCULATION OF VERTICAL DISPLACEMENTS.

The change of the refraction coefficient introduces a correction in the calculating value of Δh for all the above cases of work. This correction is given from the equation:

$$\Delta n_k = (K' - K) \frac{D^2}{2R} \quad (8)$$

where : K, K' the mean refraction coefficient's value along the intended line ,at the begining and the end of the measurements correspondly.

The refraction coefficient in each point of the lighting ray takes the value:

$$K = 668.7 \frac{P}{T^2} (0.0342 + \tau) \cos Z \quad (9)$$

where :

P=atmospheric pressure in mmHg

T=temperature in °K

τ =temperature gradient in °C/m

Z=vertical angle

Analyzing equation (9) we can see is that the vertical temperature gradient has the maximum influence in the value of refraction coefficient. The value of the vertical temperature gradient at an ordinary height is determined from the equation:

$$\tau = \frac{dT}{dh} = \alpha \beta \quad (10)$$

The coefficient α is the vertical temperature gradient at 1m height above the earth's surface. The value of coefficient β during noon hours on a sunny day is about -1 while ,during night hours ,is about -0.9 . So ,we can accepted that :

$$\tau = \frac{\alpha}{h} = \frac{\tau}{h} \quad (11)$$

The temperature gradient depends on conditions like : the season of the year, the altimeter, the degree of cloudness and surroundings .The value of temperature gradient for an ordinary height can be determined from the τ which are measured in the field. According to equation (10) ,by measuring the temperatures T_0 and T_h at corresponding heights h_0 and h ,we have:

$$\tau = \frac{T_h - T_0}{h \ln \frac{h}{h_0}} \quad (12)$$

Considering that the temperatures T_h and T_0 are measured at the altimeter $h=3m$ and $h_0=0.5m$, with an error of $\sigma T = \pm 0.1^\circ C$, we have the mean square error of the temperature gradient determination equal to : $\sigma \tau = \pm 0.08^\circ C/m$.

4.DETERMINATION OF THE INFLUENCE OF THE TEMPERATURE GRADIENT'S CHANGE IN THE COMPUTATION OF VERTICAL DISPLACEMENTS.

The value of the refraction coefficient is influenced from the value of the temperature gradient near the instrument point and the value of the temperature gradient at the control point . In trigonometric levelling the control points are usually inaccessible ,so the value of temperature gradient at this point must be determined from equation (11).According to (9) the refraction coefficients at instrument point i and at control point j ,have the form:

$$K_i = 668.7 \frac{P_i}{T_i^2} (0.0342 + \tau_i) \cos(Z+u) \quad (13)$$

$$K_j = 668.7 \frac{P_j}{T_j^2} (0.0342 + \tau_j) \cos(Z+u) \quad (14)$$

where u = the ground's inclination angle towards the intended line.The values of the temperature gradient τ_i and τ_j are:

$$\tau_i = \frac{\tau}{h_i} \quad , \quad \tau_j = \frac{\tau}{h_j} \quad (15)$$

So ,the mean refraction coefficient along the intended line is given from the equation:

$$K=668.7 \left[3 \frac{P_i}{T_i^2} \left(0.0342 + \frac{\tau}{h_i} \right) + \frac{P_j}{T_j^2} \left(0.0342 + \frac{\tau}{h_j} \right) \right] \cos(Z+u) \quad (16)$$

If $P_i=P_j=P$ and $T_i=T_j=T$ we have :

$$K=167.2 \frac{P}{T^2} \left[0.1368 + \tau \left(\frac{3h_j+h_i}{h_j h_i} \right) \right] \cos(Z+u) \quad (17)$$

And correspondly:

$$K'=167.2 \frac{P'}{T'^2} \left[0.1368 + \tau' \left(\frac{3h_j+h_i}{h_j h_i} \right) \right] \cos(Z+u) \quad (18)$$

If we determine the refraction coefficients K and K' from the equations (17) ,(18) we can determine the correction of the change of the refraction coefficient using equation (8).

The mean square error of the calculated correction is:

$$\sigma_{\Delta h_k} = \pm \frac{D^2}{2R} \sigma_{\Delta K} \quad (19)$$

If $P=P'$ and $T=T'$, then:

$$\Delta K = 167.2 \frac{P}{T^2} (\tau' - \tau) \left(\frac{3h_j + h_i}{h_j h_i} \right) \cos(Z+u) \quad (20)$$

From equations (19) and (20) we have:

$$\sigma_{\Delta h_k} = \pm 167.2 \frac{P}{T^2} \left(\frac{3h_j + h_i}{h_j h_i} \right) \frac{D^2}{2R} \cos(Z+u) \sigma_{\Delta \tau} \quad (21)$$

And for $P=760 \text{ mmHg}$, $T=290^\circ\text{K}$, $Z+u=100^\circ$ and $h_i = 1.5 \text{ m}$ then:

$$\sigma_{\Delta h_k} = \pm 1.186 \left(2 + \frac{1}{h_j} \right) d^2 \sigma_{\Delta \tau} \quad (22)$$

If we insert into the calculations the correction Δh_k , which can be calculated from measured or calculated values of τ and τ' we can not eliminate absolutely the influence of the refraction, but only minimize it. In Fig. 9. the errors, inserted into the calculations due to the differences $\Delta \tau$, appear for various conditions.

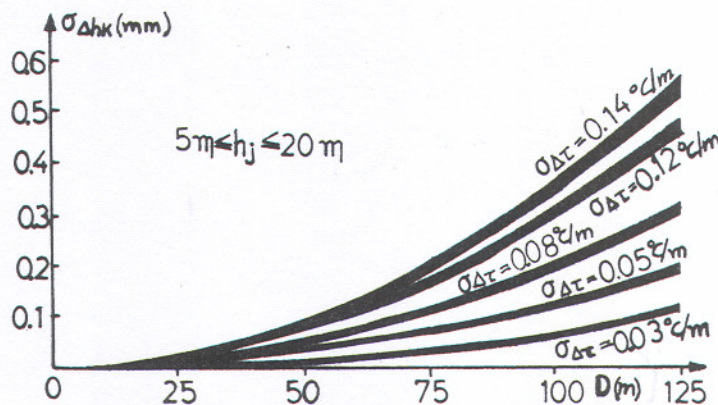

FIGURE 9 : Errors inserted into the calculations if we don't take into consideration the differences $\Delta \tau$ for various conditions.

5. SIMULTANEOUS DETERMINATION OF THE VERTICAL DISPLACEMENTS AND THE CHANGES OF THE REFRACTION COEFFICIENT.

Using the above equations we can calculate the influence of the refraction in the determination of the vertical displacements, even when the observa-

5. SIMULTANEOUS DETERMINATION OF THE VERTICAL DISPLACEMENTS AND THE CHANGES OF THE REFRACTION COEFFICIENT.

Using the above equations we can calculate the influence of the refraction in the determination of the vertical displacements, even when the observations are taken from one station only. If the observations are taken from two or more stations, then we can insert the change of the refraction coefficient as one more unknown parameter in the observation equations. If the number of exceeding observations (network's freedom degree) is small then only one value for the refraction coefficient's change for whole network can be determined.

If the number of exceeding observations is large and the distances of the intended lines are verified, then we can determine the change of the refraction coefficient for each instrument point. Using the basic trigonometric levelling equation for the determination of vertical displacements, we make the below observation equations:

- for the measured values of vertical angles to the control point:

$$\begin{aligned} & \frac{\frac{cc}{\rho}}{D_{ij}(1+\tan^2 Z_{ij})} \Delta h_j - \frac{\frac{cc}{\rho}}{D_{ij}(1+\tan^2 Z_{ij})} \Delta I_i + \frac{\frac{cc}{\rho} D_{ij}}{2R(1+\tan^2 Z_{ij})} \Delta K_{ij} = \\ & = (\Delta Z_{ij} + \frac{\Delta D_{ij}}{2D_{ij}} \frac{cc}{\rho} \sin 2Z_{ij}) + U \Delta Z_{ij} \end{aligned} \quad (23)$$

- for the measured values of vertical angles to the reference point :

$$\begin{aligned} & - \frac{\frac{cc}{\rho}}{D_{ik}(1+\tan^2 Z_{ik})} \Delta I_i + \frac{\frac{cc}{\rho} D_{ik}}{2R(1+\tan^2 Z_{ik})} \Delta K_{ik} = \\ & = \Delta Z_{ik} + \frac{\Delta D_{ik}}{2D_{ik}} \frac{cc}{\rho} \sin 2Z_{ik} + U \Delta Z_{ik} \end{aligned} \quad (24)$$

where:

i = instrument point.

j = control point.

k = reference point.

D = the horizontal distance between the points.

Z = the vertical angle between the points.

Inserting the simplifications:

$$A_{ij} = \frac{\frac{cc}{\rho}}{D_{ij}(1+\tan^2 Z_{ij})}, \quad B_{ik} = \frac{\frac{cc}{\rho}}{D_{ik}(1+\tan^2 Z_{ik})} \quad (25)$$

$$(\Delta Z)_{ij} = \Delta Z_{ij} + \frac{\Delta D_{ij}}{2D_{ij}} \frac{cc}{\rho} \sin 2Z_{ij} \quad (26)$$

$$(\Delta Z)_{ik} = \Delta Z_{ik} + \frac{\Delta D_{ik}}{2D_{ik}} \frac{cc}{\rho} \sin 2Z_{ik} \quad (27)$$

the equations (23) and (24) take the forms:

$$A_{ij} \Delta h_j - A_{ij} \Delta I_i + A_{ij} \frac{D^2_{ij}}{2R} \Delta K_{ij} = (\Delta Z)_{ij} + U \Delta Z_{ij} \quad (28)$$

$$-B_{ik} \Delta I_i + B_{ik} \frac{D^2_{ik}}{2R} \Delta K_{ik} = (\Delta Z)_{ik} + U \Delta Z_{ik} \quad (29)$$

The change of the refraction coefficient for each intended line, which is different for each instrument point, must be expressed with one common value (ΔK_o). This value may be the change of the refraction coefficient for an intended line parallel with the ground level and at a height equal to the instrument's height. From equation (20) we have:

$$\frac{\Delta K}{\Delta K_o} = \frac{\left(\frac{3h_j+h_i}{h_i h_j}\right) \sin(Z+u)}{\frac{3h_j+h_i}{h_i^2}} = \left(\frac{3h_j+h_i}{4h_j}\right) \cos(Z+u) \quad (30)$$

$$\text{or } \Delta K = \Delta K_o \left(\frac{3h_j+h_i}{4h_j}\right) \cos(Z+u) \quad (31)$$

Replacing equation (31) to the equations (28) and (29) we have the final form of the observation equations:

- for the measured values of vertical angles to the control point:

$$A_{ij} \Delta h_j - A_{ij} \Delta I_i + A_{ij} \frac{D^2_{ij}}{8R} \left(\frac{3h_j+h_i}{h_j}\right) \cos(Z+u)_{ij} \Delta K_{oi} = (\Delta Z)_{ij} + U \Delta Z_{ij} \quad (32)$$

- for the measured values of vertical angles to the reference point:

$$-B_{ik} \Delta I_i + B_{ik} \frac{D^2_{ik}}{8R} \left(\frac{3h_k+h_i}{h_k}\right) \cos(Z+u)_{ik} \Delta K_{oi} = (\Delta Z)_{ik} + U \Delta Z_{ik} \quad (33)$$

With the solution analyzed above we can get as results, the vertical displacements of the control points Δh_j , the vertical displacement of the instrument point ΔI_i and the change of the refraction coefficient ΔK_{oi} for each station. If the network's freedom degree is small, we can determine only one common value of the change of the refraction coefficient ΔK_o for the whole network.

5.1 APPLICATION

Using the solution analyzed above, the vertical displacements and the change of the refraction coefficient of the Geodetic vertical control network established at the "Peace and Friendship" Stadium of Piræus were determined. The special consolidation and the geological unstable around area of the Stadium, which is a big technical construction, make the determination of its deformations necessary.

In this application we have two networks each one consisted of 4 station points, 2 control points and 4 reference points Fig.10.

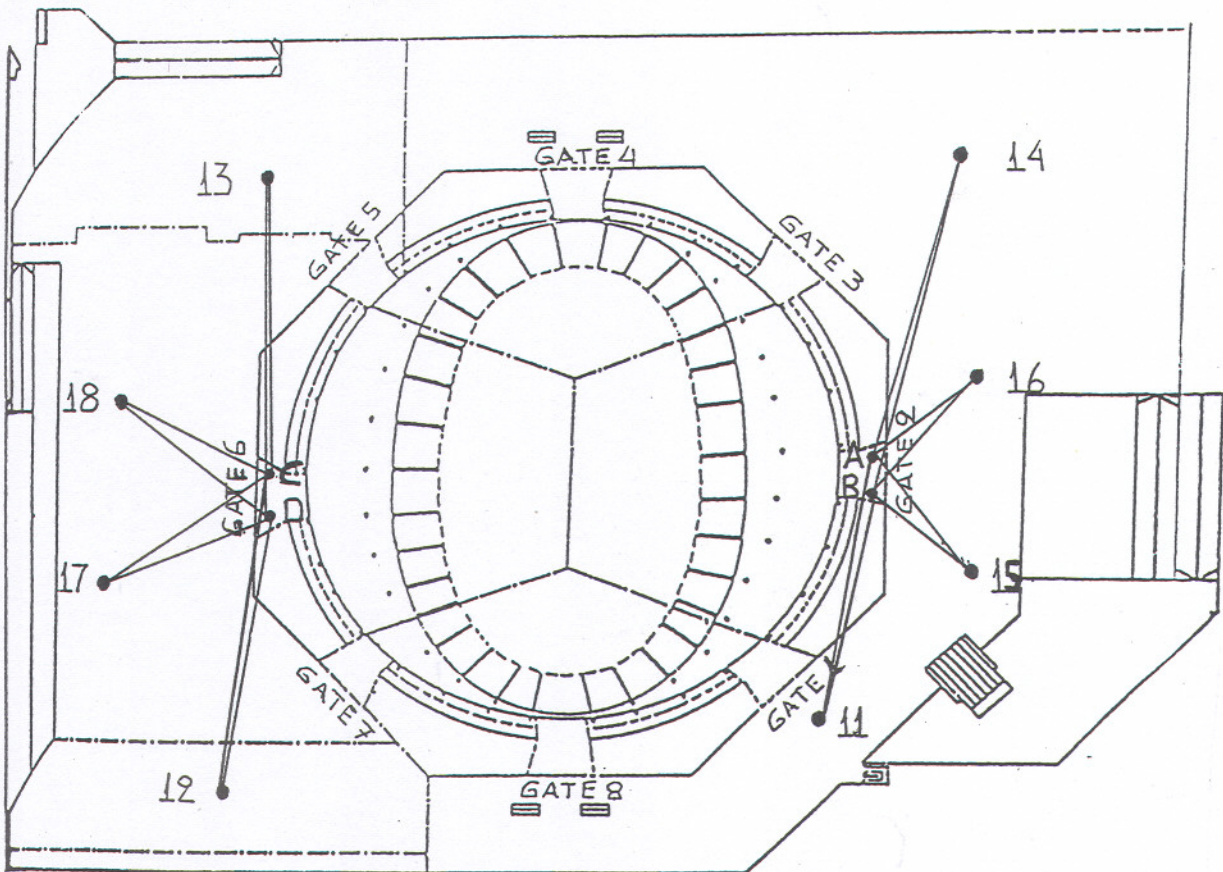

Two phases of measurements were carried out during a year (June 1988 - June 1989). The results of two different adjustment using Least Square Method appear at tables 1 and 2.

The first adjustment was done using the classical model of trigonometric levelling and the second one using the model described at chapter 5.

Points	Classical Trigonometric Method		Method of Simultaneous Determination	
	Δh_i (mm)	$\sigma \Delta h_i$ (mm)	Δh_i (mm)	$\sigma \Delta h_i$ (mm)
A	1.4	± 0.5	1.8	± 0.8
B	1.9	± 0.5	1.8	± 0.8
11	-0.5	± 0.5	-1.2	± 0.8
14	-1.1	± 0.5	-1.1	± 0.9
15	-3.4	± 0.5	-3.1	± 0.8
16	-1.5	± 0.5	-2.1	± 0.8
			$\Delta K = 0.53$	
			$\sigma \Delta K = \pm 0.34$	
	$\sigma \sigma = \pm 0.72$		$\sigma \sigma = \pm 1.03$	

TABLE 1

Points	Classical Trigonometric Method		Method of Simultaneous Determination	
	Δh_i (mm)	$\sigma \Delta h_i$ (mm)	Δh_i (mm)	$\sigma \Delta h_i$ (mm)
C	-2.3	± 0.5	-1.9	± 0.9
D	-1.9	± 0.5	-2.1	± 0.9
12	0.5	± 0.5	1.2	± 1.0
13	0.8	± 0.5	0.3	± 1.0
17	1.4	± 0.5	2.1	± 1.0
18	2.5	± 0.5	2.7	± 1.0
			$\Delta K = 0.53$	
			$\sigma \Delta K = \pm 0.39$	
	$\sigma \sigma = \pm 0.72$		$\sigma \sigma = \pm 1.47$	

TABLE 2

As we can see from the results, the two methods give almost the same magnitude of the control points' height changes. Additionally, the second adjustment (using the method of simultaneous determination) gives an estimation of the change of the refraction coefficient.

6 . REFERENCES

- BAHNERT, G (1974): Der THEO 010A des VEB Carl Zeiss Jena. Vermessung -Informationen, pp.4-8
- BILLIRIS, X (1986): Contribution in the study and the confronting of the atmosphere influences in Geodetic measurements . (In Greek). National Technical University of Athens.
- GOUGKOUTOUDIS, J (1991): Determination of Vertical displacements using trigonometric levelling and calculating methods , (Personal notes In Greek).
- GOUGKOUTOUDIS, J (1992): Accuracy of the measurements for Vertical displacements using trigonometric methods. (Personal notes ,In Greek)
- JANUSZ, W (1962): Methods of determination the theodolite speening axis inclination from the vertical, at the instrument station. (In Polish) Prace Instytutu Geodezji I Kartografii , Tom IX , Zeszyt 1(19), pp 33-69.
- LAMBROU, E - PANTAZIS, G (1990): Determination of the "Peace and Friendship" Stadium's deformations. Vertical control network establishment in the surround area . (In Greek), National Technical University of Athens . Diploma Thesis.
- LAZZARINI, T (1977): Geodetic measurements of construction displacements and surround area . (In Polish) , Geodezyjne Pomiarzy Przemieszczen Budowi I Ich Otoczenia. PPWK, Warszawa 1977.
- MARCAK, P (1971): Accuracy of measurements for the determination construction displacements using Trigonometric Levelling , (In Polish) . Przegląd Geodezyjny nr7/1971, pp.278-283.
- SOTIROPOULOS, P - STAMATIS, K - THOMA, TH - TSEMPERTZI, A (1988): Determination of the " Peace and Friendship " Stadium's deformations. (B phase). Extension of vertical control network. (In Greek) National Technical University of Athens. Diploma Thesis.
- WOJCIK, M (1985): Determination of Vertical Displacements and refraction coefficient at the same time , using Trigonometric Levelling, (In Polish). Przegląd Geodezyjny , nr11/12, 1985, pp.23-26.