Fundamentals of Blackbody Radiation

Prof. Elias N. Glytsis
November 11, 2021



School of Electrical & Computer Engineering
National Technical University of Athens

This page was intentionally left blank.....

BLACKBODY RADIATION[†]

A blackbody is an idealized physical body that can absorb all incident electromagnetic radiation independently of its frequency and its angle of incidence. At thermal equilibrium a blackbody emits all absorbed radiation. The re-emitted radiation energy depends only on its temperature. Therefore the intensity of the emitted radiation is related to the amount of energy in the body at thermal equilibrium. The history of the development of the theory of the blackbody radiation is very interesting since it led to the discovery of the quantum theory [1]. Josef Stefan, Ludwig Boltzmann, Wilhelm Wien, and finally Max Planck were instrumental in the development of the theory of blackbody radiation. A nice summary of their short biographies and the methodologies that were used to obtain their results is presented by Crepeau [2].

Early experimental studies established that the emissivity of a blackbody is a function of frequency and temperature. A measure of the emissivity can be the term $\rho(\nu, T)$ which is the density of radiation energy per unit volume per unit frequency (J/m^3Hz) at an absolute temperature T and at frequency ν . The first theoretical studies used the very successful at that point theory of Maxwell equations for the determination of the density of electromagnetic modes and from that the determination of $\rho(\nu, T)$. For example, Wilhelm Wien in 1896 used a simple model to derive the expression

$$\rho(\nu, T) = \alpha\nu^3 \exp(-\beta\nu/T) \quad (1)$$

where α, β were constants. Wien used the hypothesis that radiation was emitted by molecules which followed a Maxwellian velocity distribution and that the wavelength of radiation depended only on the molecule's velocity [2]. However, the above equation failed in the low frequency range of the experimental data.

In June 1900 Lord Rayleigh published a model based on the modes of electromagnetic waves in a cavity. Each mode possessed a particular frequency and could give away and take up energy in a continuous manner. Using the standard electromagnetic theory of a cavity resonator (see Fig. 1) with perfect conductor walls the following dispersion equation can be easily obtained [3–5] (see Appendix A) :

$$\left(\frac{m\pi}{a}\right)^2 + \left(\frac{p\pi}{b}\right)^2 + \left(\frac{q\pi}{d}\right)^2 = \left(\frac{2\pi\nu}{c}\right)^2 n^2, \quad (2)$$

[†]©2021 Prof. Elias N. Glytsis, Last Update: November 11, 2021

where n is the index of refraction of the medium, and a , b , and d are the dimensions of the cavity resonator in the x , y , and z directions, and m , p , q are positive integers.

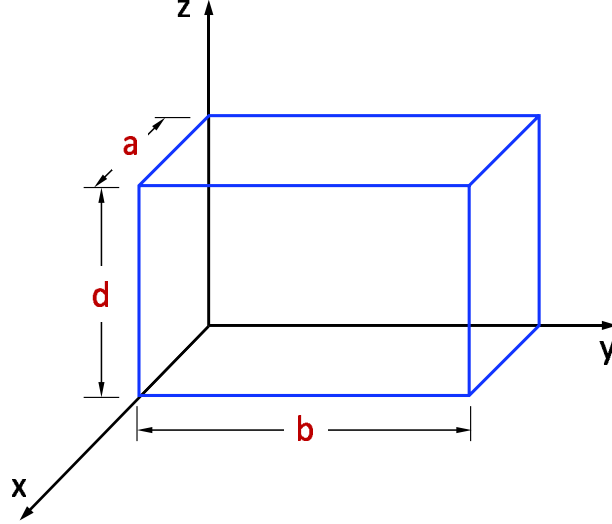

Figure 1: Cavity box for the determination of the density of electromagnetic modes.

If for simplicity it is assumed that the cavity is a cube, $a = b = d$ then the previous equation can be written as

$$m^2 + p^2 + q^2 = \left(\frac{2\nu}{c}\right)^2 a^2 n^2 = \left(\frac{2\nu n a}{c}\right)^2. \quad (3)$$

In order to count the electromagnetic modes up to frequency ν it is necessary to evaluate the number of modes that fit in the one eighth of the sphere that is shown in Fig. 2. Thus, the total number of electromagnetic modes $N(\nu)$ can be determined as follows

$$N(\nu) = \frac{(1/8) \text{ cavity volume}}{\text{volume of a mode}} = \frac{(1/8)(4/3)\pi(2\nu n a/c)^3}{1 \times 1 \times 1} = \frac{4}{3}\pi \frac{\nu^3 n^3 a^3}{c^3}. \quad (4)$$

Due to TE and TM mode degeneracy the above number should be multiplied by a factor of 2. Therefore, the total number of electromagnetic modes per volume, $\mathcal{N}(\nu)$, is

$$\mathcal{N}(\nu) = \frac{N(\nu)}{\text{Volume} = a^3} = \frac{8}{3}\pi \frac{\nu^3 n^3}{c^3}. \quad (5)$$

Then the density of electromagnetic modes per frequency is

$$\frac{d\mathcal{N}(\nu)}{d\nu} = \frac{8\pi\nu^2 n^3}{c^3}. \quad (6)$$

In the last equation it is assumed that the refractive index n is independent of frequency (or freespace wavelength). Usually for all materials there is dispersion, i.e. dependence of the refractive index on the frequency (or wavelength) of the electromagnetic radiation. In the latter case $n = n(\nu)$ and in the above derivative over frequency this dependence must be taken into account. Then the previous equation can be written as follows [6]

$$\frac{d\mathcal{N}(\nu)}{d\nu} = \frac{8\pi\nu^2 n^2 \left(n + \nu \frac{dn}{d\nu} \right)}{c^3} = \frac{8\pi\nu^2 n^2 n_g}{c^3}. \quad (7)$$

where $n_g = n + \nu(dn/d\nu) = n - \lambda_0(dn/d\lambda_0)$ (where λ_0 is the freespace wavelength) is the group refractive index and is important in materials such semiconductors and fibers where the refractive index dependence on frequency (or wavelength) can be significant. For the remainder of this section it is assumed that the refractive index is independent of frequency (or wavelength) for the sake of simplicity.

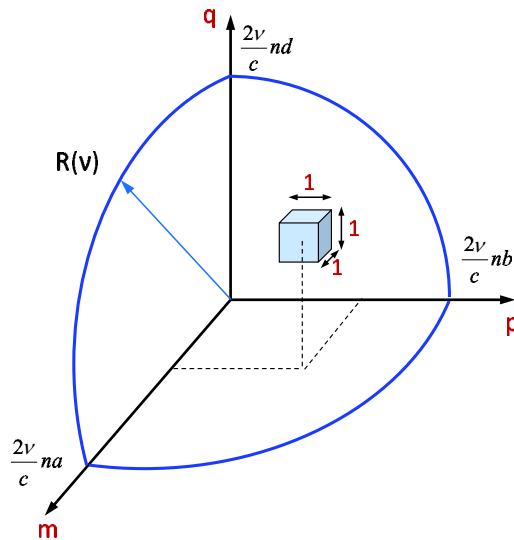

Figure 2: The one eighth of the sphere in the mpq space for the determination of the number of electromagnetic modes up to frequency ν .

Rayleigh assigned an energy $k_B T/2$ to each electromagnetic mode ($k_B T/2$ for the electric field oscillation and $k_B T/2$ for the magnetic field oscillation, where $k_B = 1.38066 \times 10^{-23} J/^\circ K$ is Boltzmann's constant). More rigorously, the average energy of each electromagnetic mode can be determined using Boltzmann's statistics [7]. According to these statistics the probability

$p(E)$ that an energy of each electromagnetic mode is between E and $E + dE$ is given by

$$p(E)dE = A \exp\left(-\frac{E}{k_B T}\right) dE, \quad (8)$$

where the constant A is a normalization constant that can be easily found from the normalization of $p(E)$ in order to represent a probability density function. Therefore, the constant A is given by

$$\int_0^\infty p(E)dE = 1 \implies A = \frac{1}{\int_0^\infty \exp(-E/k_B T) dE} = \frac{1}{k_B T}. \quad (9)$$

Then, the average energy of each electromagnetic mode can be determined from

$$\langle E \rangle = \int_0^\infty E p(E) dE = \int_0^\infty E \frac{1}{k_B T} \exp\left(-\frac{E}{k_B T}\right) dE = k_B T. \quad (10)$$

Using Eq. (6) and the average energy of Eq. (10) the electromagnetic energy density per unit frequency $\rho(\nu, T)$ becomes

$$\rho(\nu, T) = \frac{d\mathcal{N}(\nu)}{d\nu} \langle E \rangle = \frac{8\pi\nu^2 n^3}{c^3} k_B T. \quad (11)$$

The last equation is known as the Rayleigh-Jeans distribution of a blackbody radiation and fails dramatically in the ultraviolet part of the spectrum (historically referred as the “*ultraviolet catastrophe*”). This can be seen in the Rayleigh-Jeans curve of Fig. 3.

Planck used purely thermodynamic entropy arguments to derive an improved equation for Wien’s distribution law shown in Eq. (1). His derived equation was of the form [2]

$$\rho(\nu, T) = \frac{C\nu^3}{\exp(\beta\nu/T) - 1}. \quad (12)$$

It has been suggested that Planck discovered his famous constant (h) in the evening of October 7, 1900 [1]. Planck had taken into account some additional experimental data by Heinrich Reubens and Ferdinand Kurlbaum as well as Wien’s formula and he deduced in his Eq. (12), an expression that “fitted” all the available experimental data. His formula was the now known as the blackbody radiation formula given by

$$\rho(\nu, T) = \frac{8\pi\nu^2 n^3}{c^3} \frac{h\nu}{\exp(h\nu/k_B T) - 1}, \quad (13)$$

where $h = 6.62607004 \times 10^{-34} \text{ Joule} \cdot \text{sec}$ is known as Planck’s constant. The above expression reduces to Wien’s formula for high frequencies (i.e. $h\nu/k_B T \gg 1$) and to Rayleigh-Jeans

formula for low frequencies (i.e. $h\nu/k_B T \ll 1$). An example of Planck's radiation formula is shown in Fig. 3 along with Rayleigh-Jeans and Wien's approximations for a blackbody of absolute temperature $T = 6000^\circ K$.

Having obtained his formula Planck was concerned to discover its physical basis. It was hard to argue about the density of electromagnetic modes determination. Therefore, he focused on the average energy per electromagnetic mode. After discussions he had with Boltzmann regarding the number of ways of distributing discrete equal energy values among a number of molecules, Planck made the hypothesis that electromagnetic energy at frequency ν could only appear as a multiple of the step size $h\nu$ which was a quantum of energy (later it was called photon). I.e., the energy of the electromagnetic modes could be of the form $E_i = ih\nu$ where $i = 0, 1, 2, \dots$). Energies between $ih\nu$ and $(i + 1)h\nu$ do not occur. Then he used Boltzmann's statistics to compute the average energy of an electromagnetic mode. If E_0, E_1, E_2, \dots , are the allowed energies then according to Boltzmann's statistics the probability of an electromagnetic mode to have an energy E_i is

$$p(E_i) = A \exp\left(-\frac{E_i}{k_B T}\right), \quad (14)$$

and the normalization constant A is given by

$$\sum_{i=0}^{\infty} p(E_i) = 1 \implies A = \frac{1}{\sum_{i=0}^{\infty} \exp(-E_i/k_B T)} = 1 - \exp\left(-\frac{h\nu}{k_B T}\right). \quad (15)$$

Then the average energy $\langle E \rangle$ of an electromagnetic mode can be determined as follows

$$\begin{aligned} \langle E \rangle &= A \sum_{i=0}^{\infty} E_i \exp\left(-\frac{E_i}{k_B T}\right) = A [1h\nu e^{-h\nu/k_B T} + 2h\nu e^{-2h\nu/k_B T} + \dots] = \\ &= A \frac{h\nu \exp(-h\nu/k_B T)}{[1 - \exp(-h\nu/k_B T)]^2} = \frac{h\nu}{\exp(h\nu/k_B T) - 1}. \end{aligned} \quad (16)$$

Using the above calculation of the average energy of an electromagnetic mode the Planck's formula can be rewritten with the physical meaning of each of its terms

$$\rho(\nu, T) = \underbrace{\frac{8\pi\nu^2 n^3}{c^3}}_{\text{Number of em modes}} \underbrace{h\nu}_{\text{photon energy}} \underbrace{\frac{1}{\exp(h\nu/k_B T) - 1}}_{\text{Number of photons/mode}}. \quad (17)$$

Later Planck used the energy discretization of the quantum oscillator, i.e. $E_i = [(1/2) + i]h\nu$ ($i = 0, 1, 2, \dots$). Therefore, he introduced what is known today as the zero point energy, which

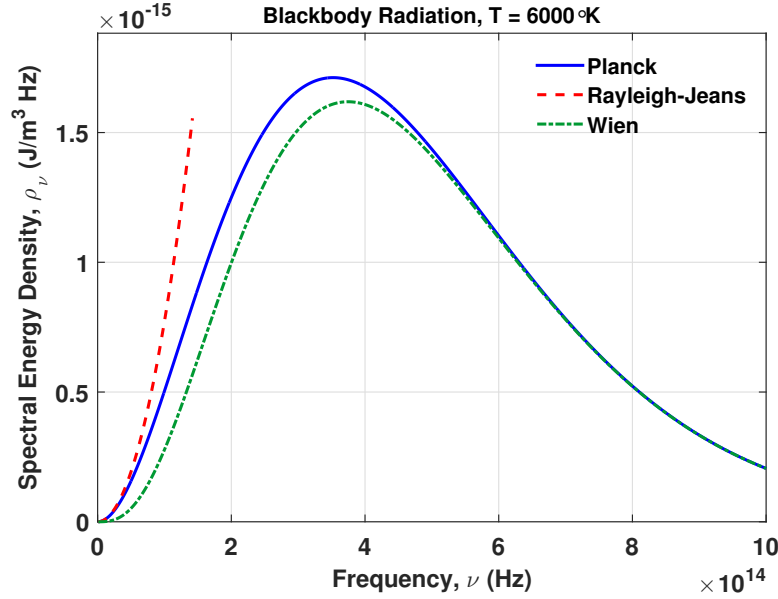

Figure 3: Blackbody radiation for $T = 6000^\circ \text{K}$. The initial theories by Rayleigh-Jeans and Wien are also shown for comparison.

is the lowest energy of a quantum oscillator. This lowest energy can not be zero due to the Heisenberg's uncertainty principle. In this case the average energy of an electromagnetic mode can be calculated in a similar manner as in Eq. (16) and is given by

$$\langle E \rangle = \frac{h\nu}{2} + \frac{h\nu}{\exp(h\nu/k_B T) - 1}, \quad (18)$$

However, in the above equation, the zero point energy $h\nu/2$ term causes increase to the radiation density $\rho(\nu, T)$ to infinity, and should not be used for the blackbody radiation energy density [8–14]. One simplistic approach to explain the absence of the zero energy term is that the photons that are either emitted or absorbed by the blackbody radiator are related to transitions between energy states $E_i - E_{i'} = (i - i')h\nu = \ell h\nu$ (where $\ell = 0, 1, 2, \dots$), and consequently the initial assumption of Planck should be used as in Eq. (16). As a general comment, the zero point energy, i. e. the vacuum energy is one of the still controversial issues of modern physics. The density of electromagnetic modes can also be expressed per wavelength (freespace) and is given by

$$\frac{d\mathcal{N}(\lambda_0)}{d\lambda_0} = -\frac{8\pi n^3}{\lambda_0^4}, \quad (19)$$

and the corresponding density of electromagnetic radiation of a blackbody per wavelength

(freespace) is

$$\rho(\lambda_0, T) = \frac{8\pi n^3}{\lambda_0^4} \frac{hc/\lambda_0}{\exp(hc/\lambda_0 k_B T) - 1}. \quad (20)$$

Frequently in the literature the blackbody radiation formula is expressed in terms of the radiant exitance (or radiant emittance) of the blackbody (in units of power/area = W/m^2). The radiant exitance expresses the total power emitted by a source in a hemisphere (towards the direction of emission) per unit area of the source. The Poynting vector expresses the power per unit area of the electromagnetic radiation. Therefore, the Poynting vector is given by $P_{avg} = (1/2\eta)|E|^2$ where E is the electric field amplitude of the electromagnetic wave, and $\eta = \sqrt{\mu_0/n^2\epsilon_0}$ is the intrinsic impedance of the non-magnetic homogeneous isotropic medium in which the electromagnetic radiation propagates. The energy density of the electromagnetic radiation is given by $w_{em} = (1/2)n^2\epsilon_0|E|^2$. Therefore, $P_{avg} = (c/n)w_{em}$. However, the energy density between ν and $\nu + d\nu$ (or equivalently between λ_0 and $\lambda_0 + d\lambda_0$) is $dw_{em} = \rho(\nu, T)d\nu = \rho(\lambda_0, T)d\lambda_0$ and then the power per unit area (between ν and $\nu + d\nu$ or equivalently between λ_0 and $\lambda_0 + d\lambda_0$) dP_{avg} can be determined as follows

$$dP_{avg} = \frac{8\pi n^2 \nu^2}{c^2} \frac{h\nu}{\exp(h\nu/k_B T) - 1} d\nu = P_{avg,\nu} d\nu, \quad (21)$$

$$dP_{avg} = \frac{8\pi n^2 c}{\lambda_0^4} \frac{hc/\lambda_0}{\exp(hc/\lambda_0 k_B T) - 1} d\lambda_0 = P_{avg,\lambda_0} d\lambda_0. \quad (22)$$

The radiance L (in $W/m^2 sr$ where $sr = steradian$) of a radiant source (that could be a blackbody radiator) is defined as $L = d^2P/dA_\perp/d\Omega$ where d^2P is the differential electromagnetic power that is emitted by the source in a specified direction, dA_\perp is the differential source area element perpendicular to the specified direction of propagation, and $d\Omega$ is the differential solid angle inside which the differential power is propagated in the specified direction [15]. A blackbody emits radiation equally in all directions and consequently it seems similarly bright from any direction observed. This means that its radiance L is constant and independent of the observation angle. Such a source is called *Lambertian* [15]. Therefore, a blackbody is always a Lambertian source. Integrating the radiance all over the solid angles it can be easily shown that $\int_\Omega L d\Omega = 4\pi L = \int (d^2P/dA_\perp) = P_{avg}$. Then the spectral radiance, dL_s of blackbody radiation between ν and $\nu + d\nu$ or λ_0 and $\lambda_0 + d\lambda_0$ can be expressed as follows

$$dL_s = \frac{dP_{avg}}{4\pi} = \frac{2n^2 \nu^2}{c^2} \frac{h\nu}{\exp(h\nu/k_B T) - 1} d\nu = L_{s,\nu} d\nu, \quad \text{and} \quad (23)$$

$$dL_s = \frac{dP_{avg}}{4\pi} = \frac{2n^2c}{\lambda_0^4} \frac{hc/\lambda_0}{\exp(hc/\lambda_0 k_B T) - 1} d\lambda_0 = L_{s,\lambda_0} d\lambda_0. \quad (24)$$

From radiometry [15] it can be easily determined that the radiance L and the radiant exitance (emittance) M (W/m^2) of a blackbody (or a Lambertian source in general) can be related from the equation $M = L\pi$. This is straightforward to show since $M = \int_{\Omega} [d^2P/(dA_s d\Omega)] d\Omega = \int_{\Omega} L \cos \theta d\Omega = \int_{\theta=0}^{\pi/2} \int_{\phi=0}^{2\pi} L \cos \theta \sin \theta d\theta d\phi = L\pi$ (where $dA_s = dA_{\perp}/\cos \theta$ and $d\Omega = \sin \theta d\theta d\phi$). Consequently $dM = \pi dL = M_{\nu}(\nu) d\nu = M_{\lambda_0}(\lambda_0) d\lambda_0 = M_{\lambda}(\lambda) d\lambda$, where M_{ν} , M_{λ_0} , and M_{λ} are the spectral exitances in $W/m^2/Hz$, $W/m^2/m$ (in freespace wavelength) and $W/m^2/m$ (inside medium wavelength), respectively. In addition, $c = \lambda_0 \nu$ and $c/n = \lambda \nu = (\lambda_0/n) \nu$. For example the radiant spectral exitance (power/unit area/frequency = $W/m^2/Hz$) of a blackbody radiator can be determined to be

$$M_{\nu}(\nu) = \frac{2\pi n^2 \nu^2}{c^2} \frac{h\nu}{\exp(h\nu/k_B T) - 1}, \quad (25)$$

while the same spectral exitance expressed per wavelength (in freespace or in medium) interval (power/unit area/wavelength = $W/m^2/m$) is given by

$$M_{\lambda_0} = \frac{2\pi n^2 c}{\lambda_0^4} \frac{hc/\lambda_0}{\exp(hc/\lambda_0 k_B T) - 1}, \quad (26)$$

$$M_{\lambda} = \frac{2\pi c}{n^2 \lambda^4} \frac{hc/\lambda}{\exp(hc/\lambda n k_B T) - 1}. \quad (27)$$

Integrating the above equations over all frequencies (or wavelengths) the radiant exitance M of a blackbody radiator at temperature T can be determined. This is known as Stefan's law and is expressed by the following equation

$$M = \int_0^{\infty} M_{\lambda_0} d\lambda_0 = \left(\frac{2\pi^5 k_B^4}{15h^3 c^2} \right) n^2 T^4 = \sigma n^2 T^4 \quad (28)$$

where $\sigma = 5.67 \times 10^{-8} W/m^2 \text{ } ^\circ K^{-4}$ = Stefan-Boltzmann constant (usually the refractive index is considered that of vacuum or air, i.e. $n \simeq 1$). The maxima of the blackbody radiator curve can be found from the solution of the equation

$$\frac{dM_{\lambda_0}(\lambda_{0,max})}{d\lambda_0} = 0 \Rightarrow \frac{hc}{\lambda_{0,max} k_B T} = 4.96511423 \Rightarrow \lambda_{0,max} T = 2897.821 \mu m \text{ } ^\circ K, \quad (29)$$

where the last part of the above equation described how the peak of the blackbody radiation shifts with the temperature and it is known as Wien's displacement law. An example of M_{λ_0} for $T = 6000 \text{ } ^\circ K$ and Wien's displacement law are shown in Fig. 4. A similar Wien's displacement

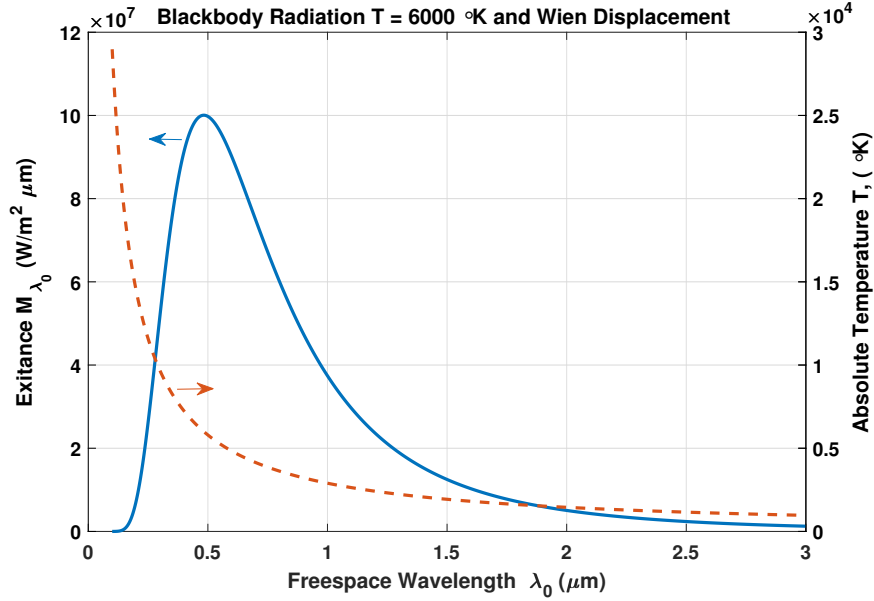

Figure 4: Blackbody radiation spectral exitance (emittance), $M_{\lambda_0}(\lambda_0)$, for $T = 6000^\circ \text{K}$ as a function of freespace wavelength. The Wien's displacement law is also shown for the same wavelength range. The maximum of M_{λ_0} occurs for $\lambda_{0,max} = 0.483 \mu\text{m}$.

law can be defined for M_ν . The maxima for M_ν can be found by

$$\frac{dM_\nu(\nu_{max})}{d\nu} = 0 \Rightarrow \frac{h\nu_{max}}{k_B T} = 2.82143937 \Rightarrow \frac{\nu_{max}}{T} = 5.878924 \times 10^{10} \text{ Hz}/^\circ\text{K}. \quad (30)$$

An example of M_ν for $T = 6000^\circ\text{K}$ and Wien's displacement law are shown in Fig. 5. It is mentioned that the peak of M_{λ_0} , $\lambda_{0,max}$, and the peak of M_ν , ν_{max} , are not related by $\lambda_{0,max}\nu_{max} = c$ since the corresponding spectral exitances are per unit wavelength and per unit frequency respectively.

An interesting point that should be discussed is the presence of the refractive index in Eq. (28). It is reminded that n corresponds to the refractive index (assuming no dispersion) of the medium that exists inside the blackbody cavity (see the calculation of the density of electromagnetic modes inside the orthogonal cavity). However, the radiated electromagnetic energy propagates away from the blackbody radiator. In many textbooks the refractive index is omitted from Eq. (28) since it is assumed that the blackbody emits radiation into vacuum or into the air (where $n_{air} \simeq 1$). This is justified because of the radiance's conservation [16, 17] between two homogeneous media of different refractive index. Let's consider a smooth boundary between two dielectric media of refractive indices of n_1 and n_2 respectively as it is shown in Fig. 6. In this figure an elementary beam of rays is incident from the left on a small

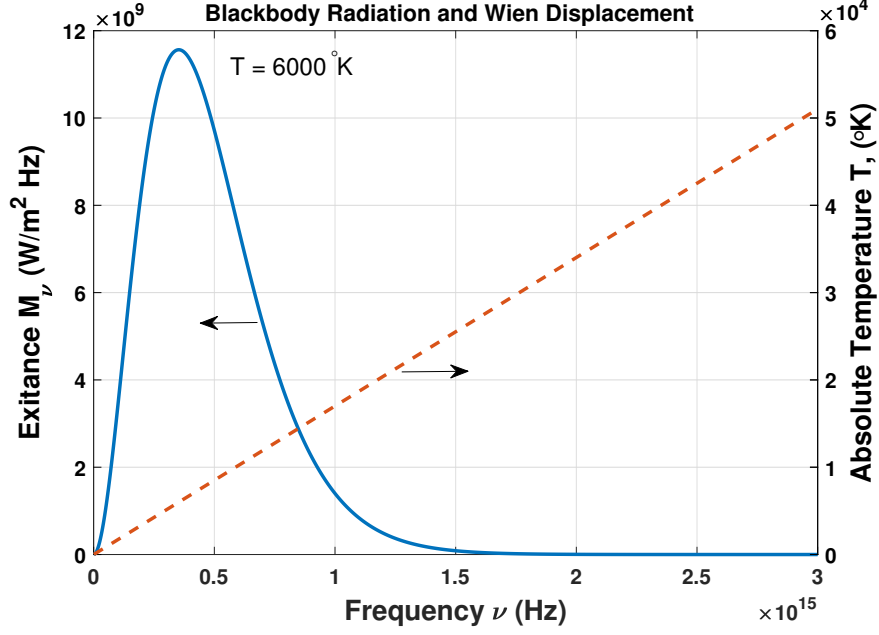

Figure 5: Blackbody radiation spectral exitance (emittance), $M_\nu(\nu)$, for $T = 6000^\circ \text{K}$ as a function of frequency. The Wien's displacement law is also shown for the same frequency range. The maximum of M_ν occurs for $\nu_{max} = 3.52 \times 10^{14} \text{ Hz}$.

area element dA of the smooth boundary [16, 17]. The normal on the differential element is assumed to represent the polar axis of a coordinate system center at the middle of the differential element with its transverse plane being in the tangential direction of the boundary (and therefore perpendicular to the plane of the interface shown in Fig. 6). Since the boundary is assumed to be smooth the Snell's law applies for the elementary rays. Therefore, $n_1 \sin \theta_1 = n_2 \sin \theta_2$. Neglecting the reflection losses (which is definitively an approximation) the power in the beam should be the same at both sides of the boundary. I.e. $d^2 P_1 = d^2 P_2$. However, $d^2 P_1 = L_1 \cos \theta_1 dA d\Omega_1 = L_1 \cos \theta_1 dA \sin \theta_1 d\theta_1 d\phi$ where ϕ lies in the transverse to the boundary plane. Similarly, $d^2 P_2 = L_2 \cos \theta_2 dA d\Omega_2 = L_2 \cos \theta_2 dA \sin \theta_2 d\theta_2 d\phi$. Differentiating the Snell's law gives $n_1 \cos \theta_1 d\theta_1 = n_2 \cos \theta_2 d\theta_2$. In order to satisfy the power conservation the following holds

$$\begin{aligned}
 d^2 P_1 &= L_1 \cos \theta_1 dA \sin \theta_1 d\theta_1 d\phi = d^2 P_2 = L_2 \cos \theta_2 dA \sin \theta_2 d\theta_2 d\phi \implies \\
 L_1 &= L_2 \frac{\cos \theta_2 d\theta_2}{\cos \theta_1 d\theta_1} \frac{\sin \theta_2}{\sin \theta_1} = L_2 \frac{n_1^2}{n_2^2} \implies \\
 \frac{L_1}{n_1^2} &= \frac{L_2}{n_2^2} = L_0 \iff \frac{M_1}{n_1^2} = \frac{M_2}{n_2^2} = M_0, \tag{31}
 \end{aligned}$$

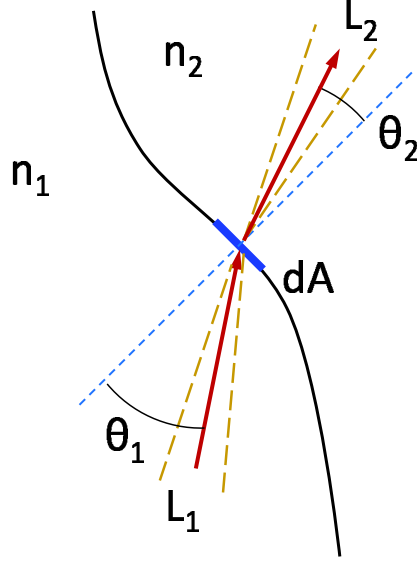

Figure 6: Radiance conservation at a smooth boundary between two homogeneous dielectric media with refractive indices n_1 and n_2 respectively.

where L_0 and M_0 are the radiance and exitance in vacuum respectively. Therefore, returning to Eq. (28) it is now obvious that $M_i = n_i^2 M_0$ where $M_0 = \sigma T^4$. This might imply that if $n_i > 1$ the exitance radiated from a dielectric medium into air could be larger than M_0 . This is not the case since some of the energy emitted within the medium of refractive index n_i is reflected back into the emitting medium at the medium-air interface due to total internal reflection of the radiation (from Snell's law the maximum angle that is refracted into the air is $\theta_{max} = \sin^{-1}(1/n_i)$ which is the critical angle). Therefore only radiation within a cone of apex angle θ_{max} will be refracted into air (neglecting reflection losses). The radiated power for an area dA (see Fig. 6) in the accepted cone can be determined as

$$\begin{aligned} dP &= \int_0^{2\pi} \int_0^{\theta_{max}} L_i dA \cos \theta \sin \theta d\phi d\theta = 2\pi L_i dA \frac{\sin^2 \theta_{max}}{2} \\ &= \pi L_i dA \frac{1}{n_i^2} = \frac{M_i}{n_i^2} dA = M_0 dA, \end{aligned}$$

and consequently the total power (per unit area) emitted by a blackbody radiator does not depend on the refractive index of the medium. Of course, in this analysis all reflections were neglected. Some discussion about taking into account the reflections is presented in Ref. [17,18].

The blackbody radiation represents the upper limit to the amount of radiation that a real body may emit at a given temperature. At any given freespace wavelength λ_0 , emissivity $\varepsilon(\lambda_0)$,

is defined as the ratio of the actual emitted radiant exitance \tilde{M}_{λ_0} over the emitted radiant exitance of a blackbody M_{λ_0} ,

$$\varepsilon_{\lambda_0} = \frac{\tilde{M}_{\lambda_0}}{M_{\lambda_0}}. \quad (32)$$

Emissivity is a measure of how strongly a body radiates at a given wavelength. Emissivity ranges between zero and one for all real substances ($0 \leq \varepsilon_{\lambda_0} \leq 1$). A gray body is defined as a substance whose emissivity is independent of wavelength, i.e. $\varepsilon_{\lambda_0} = \varepsilon$. In the atmosphere, clouds and gases have emissivities that vary rapidly with wavelength. The ocean surface has near unit emissivity in the visible regions.

For a body in local thermodynamic equilibrium the amount of thermal energy emitted must be equal to the energy absorbed. Otherwise the body would heat up or cool down in time, contrary to the assumption of equilibrium. As a result of this it can be said that materials that are strong absorbers at a given wavelength are also strong emitters at that wavelength. Similarly weak absorbers are weak emitters.

Blackbody radiation is also used to establish a color scale as a function of the absolute temperature. The *color temperature* of a light specimen is the temperature of a blackbody with the closest spectral distribution. For example, the sun has a typical color temperature of 5500° K.

APPENDIX A: Determination of Electromagnetic Modes in Rectangular Metallic Cavities

The purpose of this Appendix is to review the determination of electromagnetic modes in a rectangular-shaped cavity which is considered to have perfectly conducting walls while the material filling the cavity is homogeneous, linear and isotropic [3–5]. The approach that will be presented here is rather independent from the knowledge of the solutions of rectangular metallic waveguides solutions which is normally the traditional manner in determining the cavity modes. The rectangular cavity with the corresponding coordinate system is shown in Fig. 1. It is assumed that the determination of the TE_{mpq} modes is sought, i.e., it is assumed that $E_z = 0$ while all other field components E_x, E_y, H_x, H_y, H_z are in general nonzero. Every field component satisfies the Helmholtz equation

$$\nabla^2 S + k_0^2 n^2 S = \left(\frac{\partial^2}{\partial x^2} + \frac{\partial^2}{\partial y^2} + \frac{\partial^2}{\partial z^2} \right) S + k_0^2 n^2 S = 0, \quad (\text{A.1})$$

where $S = E_x, E_y, H_x, H_y, H_z$, $k_0 = \omega/c = 2\pi/\lambda_0$ is the freespace wavenumber, and n is the refractive index of the material inside the cavity. Because of the rectangular geometry it is reasonable to seek solutions based on the method of separation of variables, i.e., $S(x, y, z) = X(x)Y(y)Z(z)$ where $X(x) = A \cos(k_x x) + B \sin(k_x x)$, $Y(y) = C \cos(k_y y) + D \sin(k_y y)$, and $Z(z) = E \cos(k_z z) + F \sin(k_z z)$, with $k_x^2 + k_y^2 + k_z^2 = k_0^2 n^2$. From the two curl Maxwell's equations $\nabla \times \vec{E} = -j\omega\mu_0 \vec{H}$, and $\nabla \times \vec{H} = +j\omega\epsilon_0 n^2 \vec{E}$, for the TE_{mpq} modes the following equations are derived:

$$E_x = \frac{1}{j\omega\epsilon_0 n^2} \left(\frac{\partial H_z}{\partial y} - \frac{\partial H_y}{\partial z} \right), \quad (\text{A.2})$$

$$E_y = \frac{1}{j\omega\epsilon_0 n^2} \left(\frac{\partial H_x}{\partial z} - \frac{\partial H_z}{\partial x} \right), \quad (\text{A.3})$$

$$E_z = \frac{1}{j\omega\epsilon_0 n^2} \left(\frac{\partial H_y}{\partial x} - \frac{\partial H_x}{\partial y} \right) = 0, \quad (\text{A.4})$$

$$H_x = +\frac{1}{j\omega\mu_0} \frac{\partial E_y}{\partial z}, \quad (\text{A.5})$$

$$H_y = -\frac{1}{j\omega\mu_0} \frac{\partial E_x}{\partial z}, \quad (\text{A.6})$$

$$H_z = -\frac{1}{j\omega\mu_0} \left(\frac{\partial E_y}{\partial x} - \frac{\partial E_x}{\partial y} \right). \quad (\text{A.7})$$

Since the cavity is surrounded by perfect conducting walls the boundary conditions on the various field components are that the normal to the wall boundary magnetic field components are zero as well as the tangential to the boundaries electric field components. These conditions can be expressed by the following equations:

$$H_x(x = 0, y, z) = H_x(x = a, y, z) = 0, \quad (\text{A.8})$$

$$H_y(x, y = 0, z) = H_y(x, y = b, z) = 0, \quad (\text{A.9})$$

$$H_z(x, y, z = 0) = H_z(x, y, z = d) = 0, \quad (\text{A.10})$$

$$E_x(x, y = 0, z) = E_x(x, y = b, z) = E_x(x, y, z = 0) = E_x(x, y, z = d) = 0, \quad (\text{A.11})$$

$$E_y(x = 0, y, z) = E_y(x = a, y, z) = E_y(x, y, z = 0) = E_y(x, y, z = d) = 0, \quad (\text{A.12})$$

where it is reminded that for the TE_{mpq} modes $E_z = 0, \forall x, y, z$. In order to satisfy the boundary conditions for the H_x component the $X(x) = \sin(k_{xm}x)$ where $k_{xm} = (m\pi/a)$ and $m = 0, 1, \dots$. Similarly, for H_y to satisfy the boundary conditions the $Y(y) = \sin(k_{yp}y)$ where $k_{yp} = (p\pi/b)$ and $p = 0, 1, \dots$. Therefore, the solutions for H_x and H_y take the following form

$$H_x(x, y, z) = \sin\left(\frac{m\pi}{a}x\right)Y_1(y)Z_1(z), \quad \text{with} \quad \left(\frac{m\pi}{a}\right)^2 + k_y^2 + k_z^2 = k_0^2n^2, \quad (\text{A.13})$$

$$H_y(x, y, z) = X_2(x)\sin\left(\frac{p\pi}{b}y\right)Z_2(z), \quad \text{with} \quad k_x^2 + \left(\frac{p\pi}{b}\right)^2 + k_z^2 = k_0^2n^2. \quad (\text{A.14})$$

In order to force the E_z field component to be zero from Eq. (A.4) the following should hold $\forall x, y, z$,

$$\frac{1}{j\omega\epsilon_0n^2}\left\{\frac{dX_2}{dx}\sin\left(\frac{p\pi}{b}y\right)Z_2(z)\right\} = \frac{1}{j\omega\epsilon_0n^2}\left\{\sin\left(\frac{m\pi}{a}x\right)\frac{dY_1}{dy}Z_1(z)\right\} \quad \forall x, y, z. \quad (\text{A.15})$$

Using $X_2(x) = A_2 \cos(k_x x) + B_2 \sin(k_x x)$ and $Y_1(y) = C_1 \cos(k_y y) + D_1 \sin(k_y y)$ it is straightforward to show that $B_2 = 0 = D_1$, and $k_x = (m\pi/a)$, $k_y = (p\pi/b)$, and the coefficients of the $Z_1(z)$ and $Z_2(z)$ are related in such a way that the field components H_x and H_y are expressed by the following equations:

$$H_x(x, y, z) = \sin\left(\frac{m\pi}{a}x\right)\cos\left(\frac{p\pi}{b}y\right)[E_1 \cos(k_z z) + F_1 \sin(k_z z)], \quad (\text{A.16})$$

$$H_y(x, y, z) = \cos\left(\frac{m\pi}{a}x\right)\sin\left(\frac{p\pi}{b}y\right)\frac{p\pi/b}{m\pi/a}[E_1 \cos(k_z z) + F_1 \sin(k_z z)], \quad (\text{A.17})$$

where, of course $(m\pi/a)^2 + (p\pi/b)^2 + k_z^2 = k_0^2n^2$. Now in order to satisfy the boundary condition for the H_z field component the following solution is valid

$$H_z(x, y, z) = H_{0z}X_3(x)Y_3(y)\sin\left(\frac{q\pi}{d}z\right). \quad (\text{A.18})$$

From the z -dependence of H_z it is implied that the E_x and E_y field components have the following form due to Eq. (A.7)

$$E_x(x, y, z) = E_{0x}X_1(x)Y_1(y) \sin\left(\frac{q\pi}{d}z\right), \quad (\text{A.19})$$

$$E_y(x, y, z) = E_{0y}X_2(x)Y_2(y) \sin\left(\frac{q\pi}{d}z\right), \quad (\text{A.20})$$

where E_{0x} , E_{0y} are amplitude constants. Then applying Eqs. (A.5) and (A.6) for the H_x and H_y components respectively, in conjunction with Eqs. (A.16), (A.17), (A.19), and (A.20), the following conditions must be satisfied $\forall x, y, z$,

$$\begin{aligned} \sin\left(\frac{m\pi}{a}x\right) \cos\left(\frac{p\pi}{b}y\right) [E_1 \cos(k_z z) + F_1 \sin(k_z z)] &= +\frac{1}{j\omega\mu_0} \left[E_{0y} \frac{q\pi}{d} \cos\left(\frac{q\pi}{d}z\right) X_2(x) Y_2(y) \right], \\ \cos\left(\frac{m\pi}{a}x\right) \sin\left(\frac{p\pi}{b}y\right) \frac{p\pi/b}{m\pi/a} [E_1 \cos(k_z z) + F_1 \sin(k_z z)] &= -\frac{1}{j\omega\mu_0} \left[E_{0x} \frac{q\pi}{d} \cos\left(\frac{q\pi}{d}z\right) X_1(x) Y_1(y) \right]. \end{aligned}$$

From the last two equations the following solutions for the E_x , E_y , H_x , H_y fields can be obtained

$$H_x = \frac{E_{0y}}{j\omega\mu_0} \left(\frac{q\pi}{d}\right) \sin\left(\frac{m\pi}{a}x\right) \cos\left(\frac{p\pi}{b}y\right) \cos\left(\frac{q\pi}{d}z\right), \quad (\text{A.21})$$

$$H_y = \frac{E_{0y}}{j\omega\mu_0} \frac{p\pi/b}{m\pi/a} \left(\frac{q\pi}{d}\right) \cos\left(\frac{m\pi}{a}x\right) \sin\left(\frac{p\pi}{b}y\right) \cos\left(\frac{q\pi}{d}z\right), \quad (\text{A.22})$$

$$E_x = -E_{0y} \frac{p\pi/b}{m\pi/a} \cos\left(\frac{m\pi}{a}x\right) \sin\left(\frac{p\pi}{b}y\right) \sin\left(\frac{q\pi}{d}z\right), \quad (\text{A.23})$$

$$E_y = E_{0y} \sin\left(\frac{m\pi}{a}x\right) \cos\left(\frac{p\pi}{b}y\right) \sin\left(\frac{q\pi}{d}z\right). \quad (\text{A.24})$$

The last component to be determined is the H_z . Using the solutions for E_x and E_y as well as Eq. (A.7) and Eq. (A.18) the following solution for H_z is obtained

$$H_z = -\frac{E_{0y}}{j\omega\mu_0} \frac{a}{m\pi} \left[\left(\frac{m\pi}{a}\right)^2 + \left(\frac{p\pi}{b}\right)^2 \right] \cos\left(\frac{m\pi}{a}x\right) \cos\left(\frac{p\pi}{b}y\right) \sin\left(\frac{q\pi}{d}z\right). \quad (\text{A.25})$$

In order to write the equations in the usual format [?, 4] found in the literature the coefficient of the H_z component can be defined as $C = -(E_{0y}/j\omega\mu_0)(a/m\pi)k_c^2$ where $k_c^2 = (m\pi/a)^2 + (p\pi/b)^2$. Using C as the free parameter in the expressions of the fields of the TE_{mpq} mode the fields are summarized in the following form:

TE_{mpq} Modes :

$$E_x = C \frac{j\omega\mu_0}{k_c^2} \left(\frac{p\pi}{b}\right) \cos\left(\frac{m\pi}{a}x\right) \sin\left(\frac{p\pi}{b}y\right) \sin\left(\frac{q\pi}{d}z\right), \quad (\text{A.26})$$

$$E_y = -C \frac{j\omega\mu_0}{k_c^2} \left(\frac{m\pi}{a}\right) \sin\left(\frac{m\pi}{a}x\right) \cos\left(\frac{p\pi}{b}y\right) \sin\left(\frac{q\pi}{d}z\right), \quad (\text{A.27})$$

$$E_z = 0, \quad (\text{A.28})$$

$$H_x = -C \frac{1}{k_c^2} \left(\frac{m\pi}{a}\right) \left(\frac{q\pi}{d}\right) \sin\left(\frac{m\pi}{a}x\right) \cos\left(\frac{p\pi}{b}y\right) \cos\left(\frac{q\pi}{d}z\right), \quad (\text{A.29})$$

$$H_y = -C \frac{1}{k_c^2} \left(\frac{p\pi}{b}\right) \left(\frac{q\pi}{d}\right) \cos\left(\frac{m\pi}{a}x\right) \sin\left(\frac{p\pi}{b}y\right) \cos\left(\frac{q\pi}{d}z\right), \quad (\text{A.30})$$

$$H_z = C \cos\left(\frac{m\pi}{a}x\right) \cos\left(\frac{p\pi}{b}y\right) \sin\left(\frac{q\pi}{d}z\right). \quad (\text{A.31})$$

In exactly similar manner the solutions of the TM_{mpq} modes can be calculated where the $H_z = 0$. These solutions are summarized next for completeness.

TM_{mpq} Modes :

$$E_x = -D \frac{1}{k_c^2} \left(\frac{m\pi}{a}\right) \left(\frac{q\pi}{d}\right) \cos\left(\frac{m\pi}{a}x\right) \sin\left(\frac{p\pi}{b}y\right) \sin\left(\frac{q\pi}{d}z\right), \quad (\text{A.32})$$

$$E_y = -D \frac{1}{k_c^2} \left(\frac{p\pi}{b}\right) \left(\frac{q\pi}{d}\right) \sin\left(\frac{m\pi}{a}x\right) \cos\left(\frac{p\pi}{b}y\right) \sin\left(\frac{q\pi}{d}z\right), \quad (\text{A.33})$$

$$E_z = D \sin\left(\frac{m\pi}{a}x\right) \sin\left(\frac{p\pi}{b}y\right) \cos\left(\frac{q\pi}{d}z\right), \quad (\text{A.34})$$

$$H_x = D \frac{j\omega\epsilon_0 n^2}{k_c^2} \left(\frac{p\pi}{b}\right) \sin\left(\frac{m\pi}{a}x\right) \cos\left(\frac{p\pi}{b}y\right) \cos\left(\frac{q\pi}{d}z\right), \quad (\text{A.35})$$

$$H_y = -D \frac{j\omega\epsilon_0 n^2}{k_c^2} \left(\frac{m\pi}{a}\right) \cos\left(\frac{m\pi}{a}x\right) \sin\left(\frac{p\pi}{b}y\right) \cos\left(\frac{q\pi}{d}z\right), \quad (\text{A.36})$$

$$H_z = 0. \quad (\text{A.37})$$

where now D has been selected as the free parameter coefficient. For both TE_{mpq} and TM_{mpq} modes the dispersion relation and the corresponding resonance frequencies are given by the following equations

$$k_0^2 n^2 = \left(\frac{m\pi}{a}\right)^2 + \left(\frac{p\pi}{b}\right)^2 + \left(\frac{q\pi}{d}\right)^2, \quad (\text{A.38})$$

$$\omega_{mnq} = \frac{c}{n} \sqrt{\left(\frac{m\pi}{a}\right)^2 + \left(\frac{p\pi}{b}\right)^2 + \left(\frac{q\pi}{d}\right)^2}. \quad (\text{A.39})$$

REFERENCES

1. J. Baggott, *The Meaning of Quantum Theory*. New York: Oxford University Press, 1992.
2. J. Crepeau, “A brief history of the T^4 radiation law,” in *Proceedings of ASME: Heat Transfer in Energy Systems; Thermophysical Properties; Heat Transfer Equipment; Heat Transfer in Electronic Equipment*, vol. 1, (San Francisco, CA), pp. HT2009–88060, Heat Transfer Summer Conference, ASME, Jul. 19–23, 2009.
3. C. A. Balanis, *Advanced Engineering Electromagnetics*. New York: John Wiley & Sons, Inc., 2nd ed., 2012.
4. D. K. Cheng, *Fields and Waves in Electromagnetics*. New York: Addison Wesley, 2nd ed., 1989.
5. S. Ramo, J. R. Whinnery, and T. Van Duzer, *Fields and Waves in Communications Electronics*. New York: John Wiley and Sons, Inc., 3rd ed., 1993.
6. J. T. Verdeyen, *Laser Electronics*. New Jersey: Prentice Hall, 3rd ed., 1995.
7. O. Svelto, *Principles of Lasers*. New York: Springer, Inc., 5th ed., 2010.
8. J. L. Jiménez, L. de la Peña, and T. A. Brody, “Zero point term in cavity radiation,” *Amer. J. Phys.*, vol. 48, no. 10, pp. 840–846, 1980.
9. L. de la Peña and A. M. Cetto, “Plancks law as a consequence of the zeropoint radiation field,” *Rev. Mex. Fis. (Suppl. 1)*, vol. 48, pp. 1–8, Sept. 2002.
10. H. Vic Dannon, “Zero point energy: Planck radiation law,” *Gauge Institute Journal*, vol. 1, Aug. 2005.
11. F. Ogiba, “Plancks radiation law: Thermal excitations of vacuum induced fluctuations,” *Progr. Phys.*, vol. 11, no. 2, pp. 146–148, 2015.
12. L. Reggiani and E. Alfinito, “The puzzling of zero-point energy contribution to black-body radiation spectrum: The role of Casimir force,” *Fluctuation and Noise Letters*, vol. 16, no. 04, p. 1771002, 2017.

13. T. H. Boyer, “Blackbody radiation in classical physics: A historical perspective,” *Amer. J. Phys.*, vol. 86, no. 7, pp. 495–509, 2018.
14. T. H. Boyer, “Thermodynamics of the harmonic oscillator: derivation of the planck blackbody spectrum from pure thermodynamics,” *Eur. J. Phys.*, vol. 40, p. 025101, Jan. 2019.
15. W. L. Wolfe, *Introduction to Radiometry*. Tutorial Texts in Optical Engineering, vol. TT29, Bellingham, WA, USA: SPIE Press, 1998.
16. F. Grunn and R. J. Becherer, *Optical Radiation Measurements, Volume 1, Radiometry*. New York: Academic Press, Inc., 1979.
17. J. R. Howell, M. P. Mengüç, and R. Siegel, *Thermal Radiation Heat Transfer*, ch. 17. Boca Raton, FL, USA: CRC Press, Taylor & Francis Group, 6th ed., 2016.
18. J. Hartmann, “Correct consideration of the index of refraction using blackbody radiation,” *Opt. Express*, vol. 14, pp. 8121–8126, Sep. 2006.