

Reprinted from

ISSN : 1229-9367

Steel & Composite Structures

Vol. 1, No. 4(2001) 377~392

Bending and shear stiffness optimization for rigid
and braced multi-story steel frames

C.J. Gantes†, I. Vayas‡ and A. Spiliopoulos‡†

*Civil Engineering Department, National Technical University of Athens
42 Patision Avenue, GR-10682 Athens, Greece*

C.C. Pouangare‡

Consulting Engineer, 9 Nikokleous Street, Limassol, Cyprus

Techno – Press

Steel and Composite Structures, *An International Journal*

Editors-in-chief

Prof. Chang-Koon Choi (Managing Ed.)
Department of Civil Engineering
Korea Advanced Institute of Science & Technology
Daejeon 305-701, Korea
Tel : +82-42-869-3611, Fax : +82-42-869-3610
e-mail : cck@kaist.ac.kr

Prof. Siu-Lai Chan (Asian-Pacific Ed.)
Department of Civil & Structural Engineering
Hong Kong Polytechnic University
Hung Hom, Kowloon, Hong Kong
Tel : +852-2766-6047 Fax : +852-2334-6389
e-mail : ceslchan@polyu.edu.hk

Prof. David A. Nethercot (European Ed.)
Department of Civil & Environmental Engineering
Imperial College of Sci. Tech. & Medicine
London, SW7 2BU, U.K.
T: +44-207-594-6097 Fax : +44-207-594-6049
e-mail : d.nethercot@ic.ac.uk

Prof. Chia-Ming Uang (North American Ed.)
Department of Structural Engineering
University of California, San Diego
La Jolla, CA92093, U.S.A.
Tel : +1-858-534-9880 Fax : +1-858-534-6373
e-mail : cmu@ucsd.edu

International Editorial Board

Prof. D. Anderson
University of Warwick
Coventry, CV4 7AL, U.K.

Prof. M. Bradford
Univ. of New South Wales
Sydney, NSW 2052, Australia

Prof. D. Dubina
Polyt. Univ. of Timisoara
Timisoara, Romania

Prof. G. Hancock
University of Sydney
Sydney, NSW 2006, Australia

Prof. Roberto T. Leon
Georgia Inst. of Technology
Atlanta, GA 30332-0355, U.S.A.

Prof. Le-Wu Lu
Lehigh University
Bethlehem, PA 18015, U.S.A.

Prof. Keh-Chyuan Tsai
Nat'l Taiwan Univ.
Taipei, 10617 Taiwan

Prof. T. Usami
Nagoya University
Nagoya 464-01, Japan

Prof. Chitoshi Miki
Tokyo Inst. of Tech
Tokyo 152, Japan

Prof. J.M. Aribert
INSA Rennes
35043 Rennes Cedex, France

Prof. W.F. Chen
University of Hawaii
Honolulu, HI 96822, U.S.A.

Prof. Michael D. Engelhardt
University of Texas
Austin, TX 78712, U.S.A.

Prof. S. Kato
Toyohashi Univ. of Tech.
Toyohashi 441, Japan

Prof. G.Q. Li
Tongji University
Shanghai 200092, P.R. China

Prof. P. Mäkeläinen
Helsinki University of Tech.
FIN-02015 HUT, Finland

Prof. J.G. Teng
Hong Kong Polyt. Univ.
Kowloon, Hong Kong

Prof. Samuel W. Easterling
VPI & State Univ.
Blacksburg, VA 24060, U.S.A.

Prof. F.S.K. Bijlaard
Delft Univ. of Technology
2628 CN, Delft, The Netherlands

Prof. Greg G. Deierlein
Stanford University
Stanford, CA 94305-4020, U.S.A.

Prof. R. Greiner
Technical Univ. of Graz
A-8010 Graz, Austria

Prof. S. Kitipornchai
Univ. of Queensland
Brisbane, QLD 4072, Australia

Prof. R. Liew
Nat'l Univ. of Singapore
Singapore 0511, Singapore

Prof. K. Takanashi
Chiba University
Chiba 263-8522, Japan

Prof. Robert Tremblay
Ecole Polytech. Montreal
Quebec H3C 3A7, Canada

Prof. Miklos Ivany
Tech. Univ. of Budapest
Budapest, Hungary

Subscription information

The Steel & Composite Structures is published bimonthly. The subscription price for 2001 including postage by surface mail is US\$190.0 for institutional subscription and US\$95.0 for personal subscription. For delivery by air mail, add US\$25.0. Subscription orders and/or enquiries should be sent to Techno-Press, P.O. Box 33 Yuseong, Daejeon 305-600, Korea. Fax:(+82-42)869-8450. E-mail:technop3@chollian.net

Advertisement information

For details, contact: Techno-Press, P.O. Box 33 Yuseong, Daejeon 305-600, Korea. Fax:(+82-42)869-8450

Copyright © 2001 Techno-Press

published quarterly in March, June, September and December in 2001

Bending and shear stiffness optimization for rigid and braced multi-story steel frames

C.J. Gantes†, I. Vayas‡ and A. Spiliopoulos‡‡

*Civil Engineering Department, National Technical University of Athens
42 Patision Avenue, GR-10682 Athens, Greece*

C.C. Pouangare‡

Consulting Engineer, 9 Nikokleous Street, Limassol, Cyprus

Abstract. The response of multi-story building structures to lateral loads, mainly due to earthquake and wind, is investigated for preliminary design purposes. Emphasis is placed on structural systems consisting of rigid and braced steel frames. An attempt to gain a qualitative understanding of the influence of bending and shear stiffness distribution on the deformations of such structures is made. This is achieved by modeling the structure with a stiffness equivalent Timoshenko beam. It is observed that the conventional stiffness distribution, dictated by strength constraints, may not be the best to satisfy deflection criteria. This is particularly the case for slender structural systems with prevailing bending deformations, such as flexible braced frames. This suggests that a new approach to the design of such frames may be appropriate when serviceability governs. A pertinent strategy for preliminary design purposes is proposed.

Key words: rigid frame; braced frame; performance-based design; preliminary design; serviceability; stiffness equivalence; Timoshenko beam; stiffness optimization.

1. Introduction

1.1. Design requirements and strategies

The design of multi-story buildings is often governed not by gravity loads but by lateral loads, mostly caused by earthquake or wind action. This is particularly the case for buildings with high aspect ratio, defined as the ratio of the height of the building to its width at the base in the direction of the prevailing lateral action (Stafford Smith and Coull 1991, Connor and Klink 1996, Viest *et al.* 1996, Taranath 1998).

Strength based, conventional design of multi-story buildings dictates higher bending and shear strength at the base of the building, which gradually decrease with height, following the variation of bending moments and shear forces, respectively. Unlike concrete structures, where stiffness is primarily dominated by the member dimensions and strength is largely influenced by the amount of reinforcement, the

†Assistant Professor

‡Associate Professor

‡‡Ph. D. Candidate

stiffness and strength properties of standardized steel elements are much more connected to each other, so that the above strength distribution results in a more or less similar stiffness distribution. Therefore, the strength based design approach can be questionable for flexible structures, due to the fact that their response is very often governed by deflection criteria (Pouangare 1990).

In such cases it may be appropriate to reverse the common approach of designing for strength and checking for stiffness. Accordingly, the required stiffness to satisfy deformation criteria is to be derived first, followed by checking for strength (Connor and Klink 1995). This approach may then lead to different optimum stiffness distributions with height.

In the present work it is attempted to gain a qualitative understanding of the influence of bending and shear stiffness distribution on the lateral deflection response of rigid and braced multi-story steel frames (Gantes *et al.* 2000). This is achieved by modeling the structure with a stiffness equivalent beam of Timoshenko type, such that not only bending but also shear deformations are accounted for (Przemieniecki 1985). By assuming, for the sake of simplicity, linear variations of bending and shear stiffness with height, analytical expressions for the deflections can be derived. These are used to carry out parametric studies and reach qualitative conclusions regarding the optimum stiffness distributions. The main criterion for optimization is the objective of linear or near-linear deflected shape, with the maximum allowable slope (Pouangare 1990). This is viewed as a first step towards developing a preliminary design strategy for structures governed by deflection requirements.

1.2. Stiffness requirements

Frames subjected to seismic loading are designed for stiffness in order to limit their lateral deformations. This limitation refers to both the serviceability and the ultimate limit state (AISC 1995, Eurocode 3 1992); it applies, therefore, for wind as well as moderate and strong earthquakes. In the serviceability limit state lateral deformations have to be controlled primarily in order to limit the damage of non-structural elements, and also to prevent feelings of uneasiness among the occupants. In the ultimate limit state deformations must be limited in order to avoid significant influence of second order effects and to be allowed to perform the most common, first order analysis.

The structural response to lateral loads may be described by the base shear shear-top displacement curve as shown in Fig. 1 (Lu *et al.* 1997, Vayas 1997). The initial slope of the curve expresses the elastic stiffness of the structure. For the serviceability limit state, the lateral deformations calculated on the basis of the elastic stiffness correspond to the actual deformations of the structure, as the structural response is expected to be nearly elastic in the event of moderate earthquakes.

However, the actual deformations in the ultimate limit state are larger than those calculated based on the assumption of an elastic structural response. This is due to the nonlinear behavior of the structure, parts of which yield during strong earthquakes. Nevertheless, in order to avoid nonlinear analysis, most seismic design codes (AISC 1997, Eurocode 8 1994), propose a simple relationship between the nonlinear elastic-plastic and the elastic deformations. The two types of deformations are related through the value of the behavior factor q , assumed in the analysis as follows:

$$\delta = q \cdot \delta_e \quad (1)$$

where δ = actual lateral deformations for nonlinear response, and δ_e = corresponding deformations obtained by assuming linear response.

Although the above methodology constitutes an approximation of the real behavior in case of strong

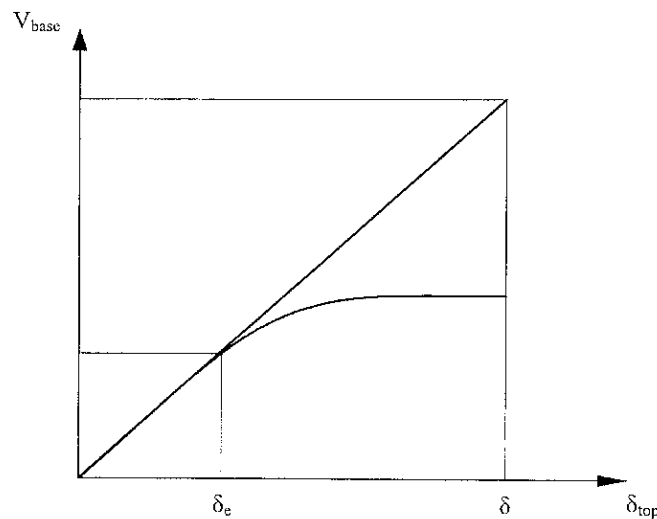

Fig. 1 Base shear top displacement curve of a frame

earthquakes, it is evident that the knowledge of the elastic lateral stiffness of a frame is important in structural design practice. Therefore, the analysis in the present paper will be based on the assumption of elastic response. Subsequent validation of the results for the real elasto-plastic response is a future research goal.

Lateral deflection constraints for multi-story buildings consist of two requirements (Eurocode 3 1992): (a) that the maximum inter-story drift is within a predefined percentage of the story height, and (b) that the total maximum drift does not exceed another predefined percentage of the total building height. It is reasonable to combine the two criteria into one, requesting a near-linear deflection line that satisfies the most stringent between the two constraints (Pouangare 1990). Thus, non-uniform local straining of structural members in regions of eventual high curvature of a nonlinear deflected shape, will be avoided.

Consequently, the objective of this paper is to study the influence of bending and shear stiffness distribution on the deflection response of multi-story buildings subjected to lateral loading. More specifically, suitable stiffness combinations will be sought, which result in a linear or near-linear deflected shape.

For preliminary design purposes, the stiffness may be determined by approximate analytical methods, thus avoiding costly numerical analyses. Such analytical approaches have been developed at times when elaborate numerical tools were less readily available than today (for example Heidebrecht and Stafford Smith 1973, Haris 1977, Stafford Smith, Kuster and Hoenderkamp 1981). Nevertheless, they still retain great value, as a means of both gaining qualitative understanding of the structural behavior and the effect of individual design parameters, and of checking numerical results (Scarlat 1996, Takewaki 1997a, 1997b).

In the present paper this approximate analysis is performed via substitution of the frame by an equivalent vertical cantilever beam having the same deformation properties, as shown in Fig. 2. This beam is subjected to deformations due to bending moments and shear forces. This is illustrated in Fig. 3, showing that the total rotation $d\delta/dx$ at any cross-section is the sum of a rotation ψ due to flexural deformation, and a rotation γ due to shear deformation. The beam has correspondingly a bending

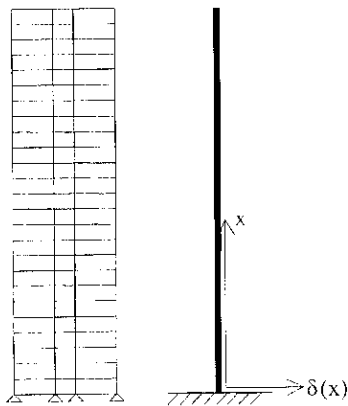

Fig. 2 Frame and equivalent vertical cantilever beam

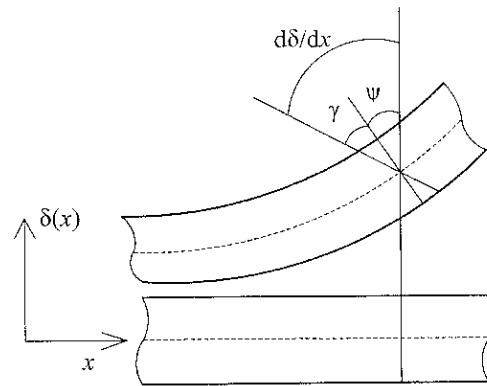

Fig. 3 Bending and shear rotation of a Timoshenko beam

stiffness, EI , and a shear stiffness, S_v . In other words, it is not a Bernoulli beam but a Timoshenko beam, and its deflected shape must be determined using Timoshenko beam theory (Pouangare 1990, Gionis 1999).

In summary, the proposed approximate analysis process consists of two steps: (i) substitution of the frame by the equivalent Timoshenko beam, and (ii) analytical calculation of the deflections of this beam. These steps are presented in sections 2 and 3 of the paper, respectively. In section 4 the results of this analysis are used to carry out a parametric study and draw conclusions on appropriate stiffness distributions for different rigid and braced frame structural systems.

2. Stiffness of equivalent beam

As mentioned above, the first step of the proposed approach is the substitution of the actual frame by a vertical Timoshenko cantilever beam. To that effect, several expressions have been derived by a number of researchers (for example Heidebrecht and Stafford Smith 1973, Haris 1977, Stafford Smith, Kuster and Hoenderkamp 1981) based on equilibrium and compatibility considerations. A systematic approach, based on the application of the direct stiffness method for a typical floor subjected to unit shear or unit bending deformation within a symbolic manipulation software, has been proposed by Gionis (1999). In the present work, simple expressions are used, derived on the basis of calculating deflections via the force method, and enforcing compatibility of deformations at the floor levels.

2.1. Diagonally and X-braced frames

In this section, the expressions of bending and shear stiffness of the equivalent beam representing the simplest case of a diagonally or X-braced, single-bay frame will be derived (Vayas 1999). In the next section the corresponding expressions for other frame configurations will be given.

A typical floor of a diagonally braced multi-story frame is shown in Fig. 4. When this structure is subjected to lateral loads, its overall behavior can be compared to that of a vertical cantilever truss. The bending moments due to external loads are resisted by axial deformations of the columns acting as flanges of this truss. The equivalent bending stiffness EI of the structure may accordingly be determined from:

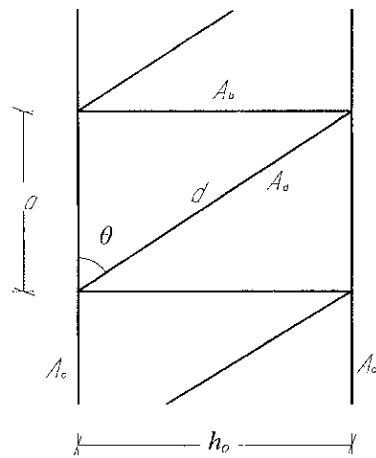

Fig. 4 Typical floor of single-bay diagonally braced frame

$$EI = \frac{EA_c h_0^2}{2} \tag{2}$$

where E is the Young's modulus of the material, A_c is the area of the cross-section of one column, and h_0 is the width of the frame, equal to the distance between the centerlines of the columns.

For the evaluation of the shear stiffness of a typical floor, a unit transverse force $V = 1$ is applied and the axial forces in the members are determined, as shown in Fig. 5. The resulting lateral deformation is determined by means of the force method:

$$\delta_s = \sum_i \frac{N_i^2}{EA_i} l_i \tag{3}$$

where N_i are the axial forces in the i^{th} truss member due to the unit shear load, and A_i are the areas of the corresponding cross-sections, namely A_d is the cross-sectional area of the diagonal and A_b of the beam. The application of Eq. (3) to the specific frame of Fig. 4 gives:

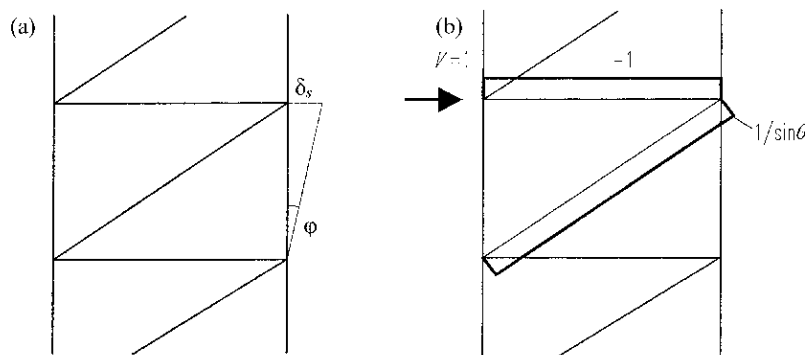

Fig. 5 Deformation (a) and axial forces (b) of typical floor of single-bay diagonally braced frame subjected to unit shear

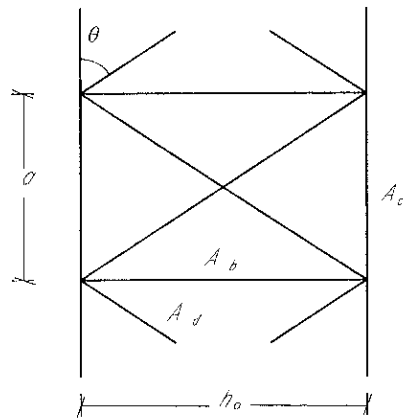

Fig. 6 Typical floor of single-bay X-braced frame

$$\delta_s = \frac{d}{\sin^2 \theta EA_d} + \frac{h_o}{EA_b} \quad (4)$$

The shear deformation of the truss, defined by the angle of sway, is given by:

$$\varphi = \frac{\delta_s}{a} \quad (5)$$

The shear stiffness is determined from:

$$S_v = \frac{V}{\varphi} = \frac{1}{\varphi} \quad (6)$$

Substituting (4) and (5) into (6) and eliminating the lengths of the members leads to the following expression for the shear stiffness:

$$S_v = \frac{1}{\frac{1}{EA_d \sin^2 \theta \cos \theta} + \frac{1}{EA_b \cot \theta}} \quad (7)$$

For the X-braced frame of Fig. 6, where two diagonals participate in the shear force transfer, the relevant expression may be written as:



$$S_v = \frac{1}{\frac{1}{2EA_d \sin^2 \theta \cos \theta} + \frac{1}{EA_b \cot \theta}} \quad (8)$$

However, if in X-braced frames the contribution of the compression diagonal is neglected due to buckling, Eq. (7) instead of Eq. (8) should be used.

2.2. Other types of frames

The bending stiffness of other single-bay frames is determined in the same manner as for diagonally

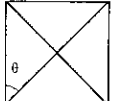
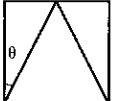
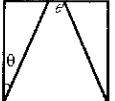
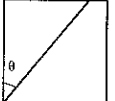
Table 1 Shear stiffness of typical single-bay frames

	$S_v = \frac{1}{\frac{1}{S_1} + \frac{1}{S_2}}$
	$S_v = \frac{1}{\frac{1}{2S_1} + \frac{1}{S_2}}$
	$S_v = \frac{1}{\frac{1}{2S_1} + \frac{1}{2S_2}}$
	$S_v = \frac{1}{\frac{1}{2S_1} + \frac{1}{2S_2} + \frac{\epsilon}{2S_3} + \frac{\phi(1-\epsilon)}{8S_4}}$
	$S_v = \frac{1}{\frac{1}{S_1} + \frac{1}{S_2} + \frac{\epsilon}{\psi S_3} + \frac{\phi\psi(1-\epsilon)}{S_4}}$
	$S_v = 3EA_b \frac{h_b^2}{ah_o}$

S_1 : Eq. (9), S_2 : Eq. (10), S_3 : Eq. (11), S_4 : Eq. (12), ϵ : Eq. (13), ϕ : Eq. (14), r : Eq. (15), ψ : Eq. (16)

or X-braced frames, from Eq. (2). The shear stiffness is determined by applying similar procedures to the one adopted for diagonally braced frames, namely via the force method. The results for several typical structural systems of braced frames and a single-bay rigid frame are summarized in Table 1. The expressions of Table 1 are explained in the following equations, where G is the shear modulus of the material, A_{bv} the shear area of the beam cross-section, I_b and I_d the moments of inertia of the cross-sections of beam and diagonal, respectively, and h_b is the height of the cross-section of the beam.

$$S_1 = EA_d \sin^2 \theta \cos \theta \quad (9)$$

$$S_2 = EA_b \cot \theta \quad (10)$$

$$S_3 = GA_{bv} \tan \theta \quad (11)$$

$$S_4 = \frac{3EI_b \tan \theta}{e^2} \quad (12)$$

$$\epsilon = \frac{e}{h_o} \quad (13)$$

$$\phi = r(1 - \epsilon) + \epsilon \quad (14)$$

$$r = \frac{1}{1 + \mu \frac{I_d}{I_b} \sin \alpha} \tag{15}$$

$$\psi = 1 - \varepsilon \tag{16}$$

where $\mu = 0$ if the braces are pin-connected at their ends, $\mu = 1$ if the braces are rigidly connected to the beam and pin-connected at the far end, and $\mu = 4/3$ if the braces are rigidly connected at both ends.

By using the equivalent stiffness expressions proposed in this section, it is possible to model the overall deflection behavior of braced or rigid single-bay frames due to lateral loads by studying the response of a vertical cantilever Timoshenko beam. The distribution of bending and shear stiffness of the Timoshenko beam with height is directly related to the member properties in individual floors. Similar equivalent stiffness expressions can be derived for multi-bay frames. The deflections of the equivalent beam can in many cases be obtained analytically, thus providing the designer with a very fast and inexpensive tool for preliminary design and for qualitative investigation.

3. Deflections of equivalent beam

3.1. Governing equations

As outlined before, a multi-story frame can be substituted by a simple, cantilever, Timoshenko beam that is equivalent with respect to stiffness. The equivalent properties of the beam cross section are its bending stiffness, EI , and its shear stiffness, S_v . The beam is subjected to a distributed lateral load, simulating equivalent static wind or earthquake excitation. For the sake of simplicity, the stiffness properties and the lateral loads are considered in this analysis to vary linearly along the height of the beam as shown in Fig. 7. This assumption leads to a simple analytical solution for the deflections, but it by no means narrows the range of applicability of the proposed approach, as any other distribution could be treated by similar means.

The relevant expressions for the stiffness properties and the lateral loading may then be written as:

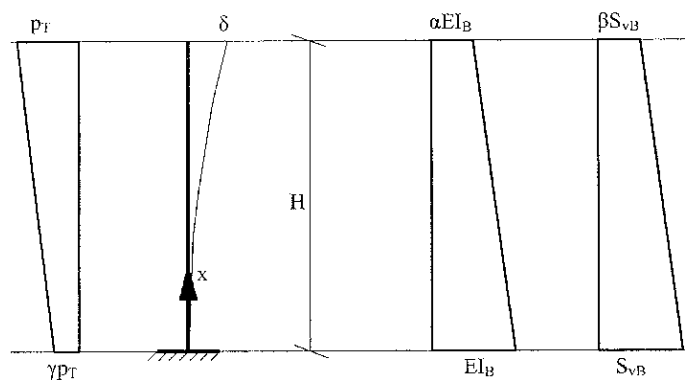

Fig. 7 Loading, deflected shape, and stiffness distribution of equivalent cantilever beam

$$p(\xi) = p_T(\gamma + \xi - \gamma\xi) \quad (17)$$

$$EI(\xi) = EI_B(1 - \xi + \alpha\xi) \quad (18)$$

$$S_v(\xi) = S_{vB}(1 - \xi + \beta\xi) \quad (19)$$

where

$$\xi = \frac{x}{H} \quad (20)$$

The system of differential equations of equilibrium for this beam is given by:

$$-(EI\psi')'' = -p \quad (21)$$

$$S_v(\delta' - \psi) = -(EI\psi')' \quad (22)$$

where ' denotes differentiation with respect to x . For given stiffness distributions, these equations can be solved analytically for the deflections δ and the flexural rotations ψ , taking into account the appropriate boundary conditions:

- zero deflection at the base:

$$\delta(0) = 0 \quad (23)$$

- zero bending rotation at the base:

$$\psi(0) = 0 \quad (24)$$

- zero bending moment at the top:

$$M(H) = 0 \Rightarrow \psi'(H) = 0 \quad (25)$$

- zero shear force at the top:

$$V(H) = 0 \Rightarrow \gamma(H) = 0 \Rightarrow \delta'(H) - \psi(H) = 0 \quad (26)$$

Here, a slightly different approach will be employed to obtain the deflections, namely the force method.

3.2. Calculation of deflections with the force method

The shear forces and bending moments due to the external loads and a unit horizontal force at the position x , where the displacement is to be determined are, respectively, equal to:

- Due to external loads:

Shear force:

$$V(\xi) = \frac{1}{2}p_T(1 + \gamma + \xi - \gamma\xi)(1 - \xi)H \quad (27)$$

Bending moment:

$$M(\xi) = \frac{1}{6}p_T(2 + \gamma + \xi - \gamma\xi)(1 - \xi)^2H^2 \quad (28)$$

- Due to a unit force at the position $\xi_0 = x_0/H$:
Shear force:

$$\bar{V}(\xi) = \begin{cases} 1, & \xi \leq \xi_0 \\ 0, & \xi > \xi_0 \end{cases} \quad (29)$$

Bending moment:

$$\bar{M}(\xi) = \begin{cases} \xi_0 - \xi, & \xi \leq \xi_0 \\ 0, & \xi > \xi_0 \end{cases} \quad (30)$$

The lateral deformations at position ξ_0 may be determined by summing up the bending and shear deformations, δ_b and δ_s , respectively:

$$\delta = \delta_b + \delta_s \quad (31)$$

Using the force method, δ_b and δ_s are obtained by appropriate integration:

$$\delta_b = \int_0^{x_0} \frac{M\bar{M}}{EI} dx \quad (32)$$

$$\delta_s = \int_0^{x_0} \frac{V\bar{V}}{S_v} dx \quad (33)$$

By executing the integration the following expressions are found for the deformation at any position ξ :

$$\delta_b = \frac{H^4 p_T D_B}{6EI_B} \quad (34)$$

$$\delta_s = \frac{H^2 p_T D_S}{2S_{vB}} \quad (35)$$

where

$$\begin{aligned} D_B = & \frac{1}{12(\alpha-1)^5} \{ (1-a)\xi \{ \alpha^2 [-36-18(3+2\gamma)\xi + (2+16\gamma)\xi^2 + 3(1-\gamma)\xi^3] \\ & + \xi[-12+2\xi+\xi^2 - \gamma(6-4\xi+\xi^2)] + \alpha\xi[48-4\xi-3\xi^2 + \gamma(24-14\xi+3\xi^2)] \\ & + \alpha^3[24+18\xi-\xi^3 + \gamma(12+18\xi-6\xi^2+\xi^3)] \} \\ & + 12\alpha^2[-3+\alpha(2+\gamma)] \cdot [1+(\alpha-1)\xi] \log[1+(\alpha-1)\xi] \} \end{aligned} \quad (36)$$

$$\begin{aligned} D_S = & \frac{1}{2(\beta-1)^3} \{ (\beta-1)\xi[2+\xi-\beta\xi + \gamma(2-4\beta-\xi+\beta\xi)] \\ & + 2\beta(-2+\beta+\beta\gamma) \cdot \log[1+(\beta-1)\xi] \} \end{aligned} \quad (37)$$

are dimensionless quantities representing the relative significance of bending and shear deformations, respectively.

The total deformation, obtained by adding δ_b and δ_s , may be written as:

$$\delta = \frac{p_T H^2}{2S_{vB}} \left(\rho_M \frac{D_B}{3} + D_S \right) \quad (38)$$

where:

$$\rho_M = \frac{S_{vB} H^2}{EI_B} \quad (39)$$

is a factor describing the relative importance of shear stiffness with respect to bending stiffness at the base; and depends primarily on the structural system.

The base shear is equal to:

$$V_B = \frac{1}{2} p_T (1 + \gamma) H \quad (40)$$

Inserting Eq. (40) into Eq. (38) the total lateral deformation is obtained in dimensionless form as:

$$\frac{\delta}{H} \cdot \frac{S_{vB}}{V_B} = \frac{1}{1 + \gamma} \cdot \left(\frac{1}{3} \rho_M D_B + D_S \right) \quad (41)$$

4. Analysis results

4.1. Performance criteria

All seismic codes provide limitations for inter-story drifts in order to limit the damage in non-structural elements, as well as reduce second order effects, thus rendering the ordinary linear analysis methods that ignore them more reliable. In addition, limits are imposed on the maximum total drift on top of the building. The two criteria can be combined, so that the design target is a uniform, as far as possible, drift distribution over the height of the building, suggesting a linear variation of lateral deflections.

A fundamental assumption of the proposed approach must also be reminded here, namely that elastic deformations, as obtained by the above analysis, are considered to adequately represent the deformations of the real, elasto-plastic system. This assumption is in accordance to most codes, which suggest to obtain elasto-plastic displacements by multiplying elastic ones with an appropriate behavior factor. However, qualitative conclusions obtained according to this assumption must in future be verified by means of elasto-plastic analyses.

4.2. Numerical results

Eqs. (41) and (39) indicate that for low values of ρ_M the shear deformations are prevailing, while for high values of ρ_M the bending deformations are more important.

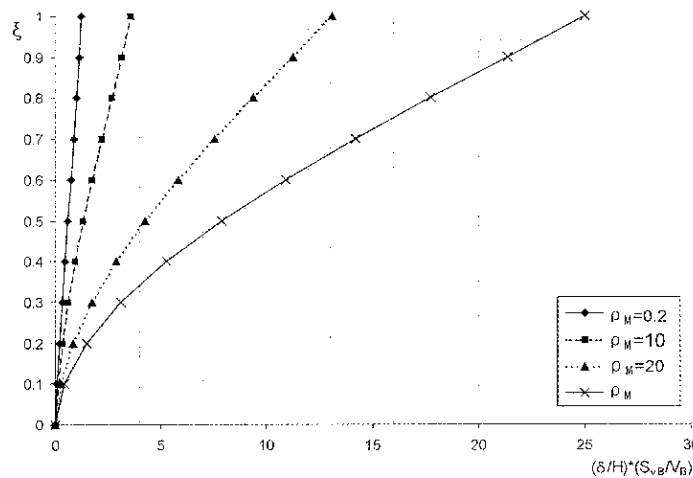

Fig. 8 Variation of drift along the height of the building for $\alpha = \beta = 0.1$ and values of ρ_M between 0.2 and 100, for triangular loading ($\gamma = 0$)

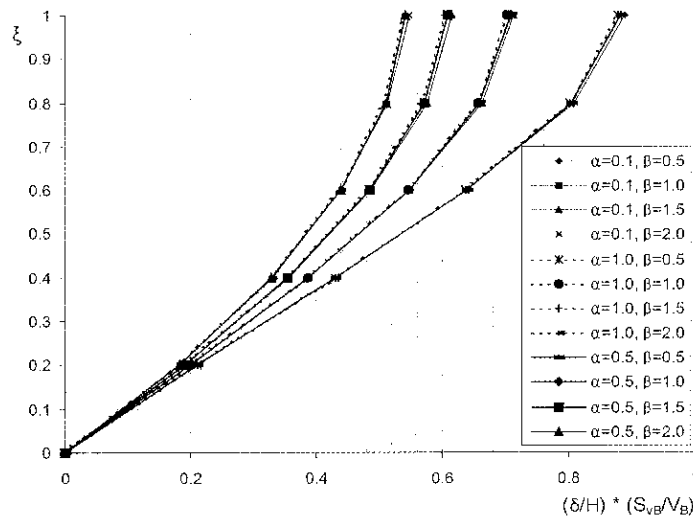

Fig. 9 Variation of drift along the height of the building for $\rho_M = 0.2$, α between 0.1 and 1, and β between 0.5 and 2, for triangular loading ($\gamma = 0$)

It is reminded that according to Fig. 7 and Eqs. (18) and (19), values of the parameters α and β smaller than 1 correspond by definition to a reduction in stiffness, and therefore, normally, in strength as well, along the height of the building.

The variation of the nondimensionalized deformation along the height of the building for the case of triangular loading ($\gamma = 0$) is presented in Figs. 8, 9 and 10 for various values of the parameters ρ_M , α and β .

Fig. 8 shows the influence of parameter ρ_M for a case of decreasing stiffness along the height of the building. It is observed that for low values of ρ_M , where shear deformations govern the response, the design target of linear variation of the lateral deformations is best achieved by a reduction in both bending and shear stiffness over the height of the structure, defined here by values of the parameters α

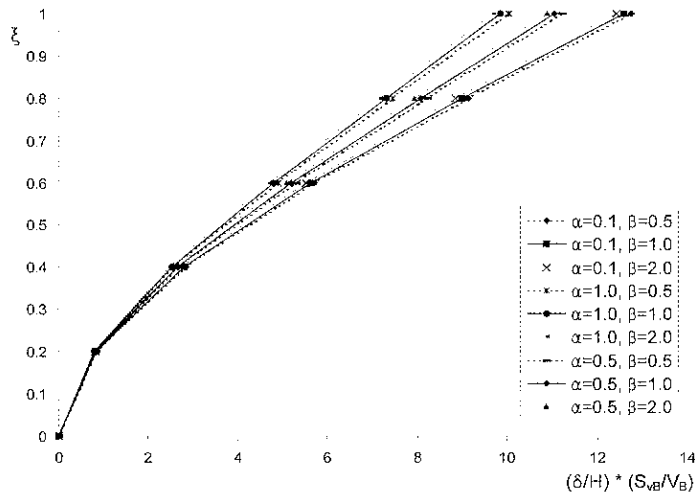

Fig. 10 Variation of drift along the height of the building for $\rho_M = 50$, α between 0.1 and 1, and β between 0.5 and 2, for triangular loading ($\gamma = 0$)

and β equal to 0.1. However, for increasing values of ρ_M the deformation line becomes increasingly nonlinear, in a flexural manner, if this stiffness distribution is maintained.

This is also verified by Fig. 9, where ρ_M is kept constant, equal to 0.2, so that shear deformations govern, while α is varied between 0.1 and 1, and β between 0.5 and 2. The influence of the bending stiffness distribution parameter α is insignificant in this case of prevailing shear response. Again, the design target is best served by small values of β , which suggests decreasing shear stiffness with height.

In the case of mostly flexural buildings, characterized by increasing ρ_M , better results are achieved for higher α values, as illustrated by Fig. 10. As expected, the lateral deformations are mostly influenced by the distribution of the bending stiffness (parameter α) for such buildings with prevailing bending deformations. On the contrary, the influence of shear stiffness distribution (parameter β) is practically insignificant.

4.3. Discussion of results

As already mentioned, strength based, conventional wisdom dictates higher bending and shear strength at the base of the building, which gradually decreases with height, following the variation of bending moment and shear force, respectively. Using Eqs. (27) and (40) the ratio of applied shear force to base shear, is given by:

$$\frac{V}{V_B} = \frac{(1 + \gamma + \xi - \gamma\xi)(1 - \xi)}{1 + \gamma} \tag{42}$$

Similarly, the ratio of externally applied overturning moment to the overturning moment at the base of the structure is given by:

$$\frac{3M}{2V_B H} = \frac{(2 + \gamma + \xi - \gamma\xi)(1 - \xi)^2}{2(1 + \gamma)} \tag{43}$$

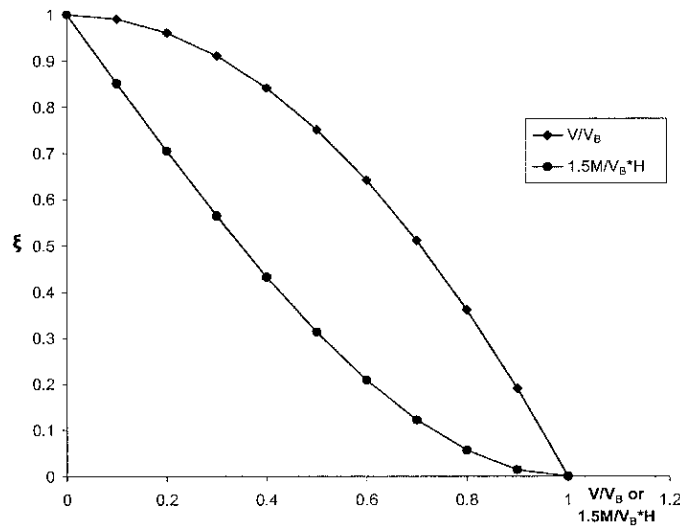

Fig. 11 Variation of demand in shear and bending strength over the height of the building for triangular lateral loading ($\gamma=0$)

Eqs. (42) and (43) are presented graphically for the case of triangular loading ($\gamma=0$) in Fig. 11. The curves express the requirements of the building in shear and bending strength. For braced frames these requirements correspond primarily to requirements for the dimensions of braces and columns, respectively. As expected, the requirements decrease from the top to the base of the structure.

Considering, as explained before, that the variation of strength is not very much deviating from the variation in stiffness, a discrepancy is found for structures with high value of ρ_M , and accordingly prevailing bending deformations. The strength requirements suggest the adoption of low α and β -values, while the serviceability requirements, as discussed before, are served better by high α and β -values. This constitutes a disadvantage for slender bracing systems with large height-to-width ratios, in which the bending deformations prevail.

Figs. 12 to 14 illustrate types of buildings for which the above discussion is relevant. The rigid frames of Fig. 12 deform primarily as shear cantilevers, when subjected to lateral loads. Therefore, there is no

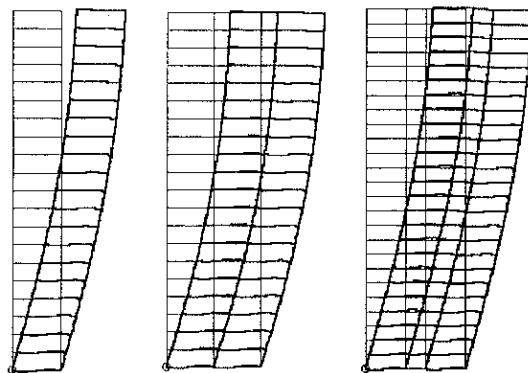

Fig. 12 Rigid frames with prevailing shear mode of lateral deformation

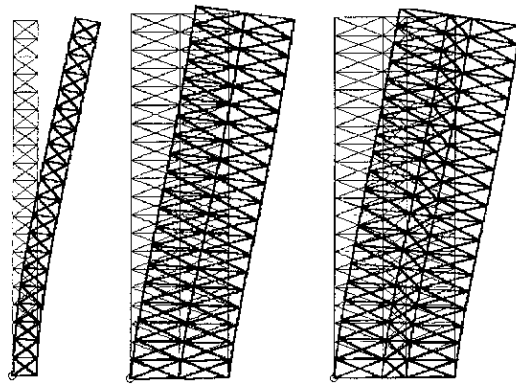

Fig. 13 Braced frames with prevailing flexural or combined shear-flexural mode of lateral deformation

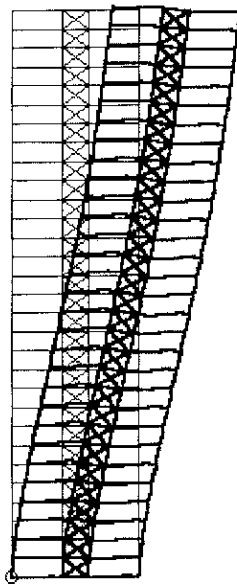

Fig. 14 Mixed rigid-braced frame with combined shear-flexural mode of lateral deformation

discrepancy between the stiffness distributions resulting from strength and deflection requirements.

Slender braced frames with high aspect (height to width) ratio, such as the first example of Fig. 13, deform primarily as flexural cantilevers. For such structures a design governed by deflection requirements will result in different stiffness distributions than one for which strength criteria prevail.

The other two braced frames of Fig. 13 with higher aspect ratios, as well as the combined rigid and braced frames like the one shown in Fig. 14 constitute intermediate cases, for which further analysis is needed.

5. Conclusions

The response of multi-story steel building structures subjected to lateral loads has been investigated for preliminary design purposes. A simplified analysis method has been suggested, based on substitution of

the building by a stiffness-equivalent Timoshenko beam. The results of this analysis have been used to gain qualitative understanding of the influence of bending and shear stiffness distribution on the deflection response of such structures. A design criterion has been established that requires linear or near-linear deflection distribution along the height. It has been observed that the conventional stiffness distribution, dictated by strength constraints, is not the best to satisfy this deflection criterion in the case of flexible braced frames. This suggests that a new approach to the design of such frames may be appropriate when deflection criteria govern.

References

- American Institute of Steel Construction (1995), *Load and Resistance Factor Design (LRFD)*.
- American Institute of Steel Construction (1997), *Seismic Provisions of Structural Steel Buildings*.
- Connor, J.J. and Klink, B.S.A. (1995), "A methodology for motion based design", *Proc. A New Direction in Seismic Design*, Tokyo, Japan, 9-10 Oct.
- Connor, J.J. and Klink, B.S.A. (1996), *Introduction to Motion Based Design*, WIT Press, Southampton.
- European Committee for Standardization (CEN) (1992), *Eurocode 3: Design of Steel Structures, Part 1.1: General Rules and Rules for Buildings*, ENV 1993-1.1.
- European Committee for Standardization (CEN) (1994), *Eurocode 8: Design Provisions for Earthquake Resistance of Structures, Part 1.3: General Rules Specific Rules for Various Materials and Elements*, ENV 1998-1.3.
- Gantes, C.J., Vayas, I., Spiliopoulos, A. and Pouangare, C.C. (2000), "Optimum bending and shear stiffness distribution for performance based design of rigid and braced multi-story steel frames", *Proc. of Behaviour of Steel Structures in Seismic Areas, STESSA 2000*, Montreal, Canada, 21-24 Aug.
- Gionis, G.A. (1999), "A new method for the preliminary design of high-rise buildings", Diploma thesis, Civil Engineering Department, National Technical University of Athens, Greece (in Greek).
- Haris, A.A.K. (1977), "Approximate stiffness analysis of high-rise buildings", *J. Struct. Div.*, ASCE, **104**(ST4), August.
- Heidebrecht, A.C., Stafford Smith, B. (1973), "Approximate analysis of tall wall-frame structures", *J. Struct. Div.*, ASCE, **99**(ST2), February, 199-221.
- Lu, L.-W., Ricles, J.M. and Kasai, K. (1997), "Global performance, general report", *Proc. Behaviour of Steel Structures in Seismic Areas, STESSA 97*, Kyoto, Japan.
- Pouangare, C.C. (1990), "New design concepts for tall buildings", Ph.D. thesis, Department of Civil Engineering, Massachusetts Institute of Technology, Cambridge, MA.
- Przemieniecki, J.S. (1985), *Theory of Matrix Structural Analysis*, Dover.
- Scarlat, A.S. (1996), *Approximate Methods in Structural Seismic Design*, E. & F.N. Spon, London.
- Stafford Smith, B., Kuster, M. and Hoenderkamp, J.C.D. (1981), "A generalized approach to the deflection analysis of braced frame, rigid frame and coupled wall structures", *Canadian Journal of Civil Engineering*, **8**, January, 230-239.
- Stafford Smith, B. and Coull, A. (1991), *Tall Building Structures: Analysis and Design*, John Wiley & Sons, Inc., New York.
- Takewaki, I. (1997a), "Efficient semi-analytical generator of initial stiffness designs for steel frames under seismic loading Part 1: Fundamental frame", *The Structural Design of Tall Buildings*, **6**, 151-162.
- Takewaki, I. (1997b), "Efficient semi-analytical generator of initial stiffness designs for steel frames under seismic loading Part 2: Slender frame", *The Structural Design of Tall Buildings*, **6**, 163-170.
- Taranath, B.S. (1998), *Steel, Concrete, & Composite Design of Tall Buildings*, McGraw-Hill, New York.
- Vayas, I. (1997), "Stability and ductility of steel elements", *J. Constr. Steel Res.*, **44**(1-2), 23-50.
- Vayas, I. (1999), "Design of braced frames", in F.M. Mazzolani, V. Gioncu (Eds), *Seismic Resistant Steel Structures*, International Centre for Mechanical Sciences (CISM), Courses and lectures No 420, Springer Verlag, 241-288.
- Viest, I.M., Colaco, J.P., Furlong, R.W., Griffis, L.G., Leon, R.T. and Wyllic L.A. Jr. (1996), *Composite Construction Design for Buildings*, McGraw-Hill, New York.

Aims and Scopes

Steel & Composite Structures, *An International Journal*, provides an excellent publication channel which reports the up-to-date research developments in the steel and steel-concrete composite structures from the international steel engineering community. The research results reported in this journal address all the aspects of theoretical and experimental research, including Buckling/Stability, Fatigue/Fracture, Fire Performance, Connections, Frames/Bridges, Plates/Shells, Composite Structural Components, Hybrid Structures, Fabrication/Maintenance, Design Codes, Dynamics/Vibrations, Nonferrous Metal Structures, and Analytical Methods. The Journal specially wishes to bridge the gap between the theoretical developments and practical applications for the benefits of both academic researchers and practicing engineers. In this light, contributions from the practicing engineers are especially welcome.

Instruction to Authors

1. Submission of the paper

Authors may submit manuscripts on diskettes as well as three hard copies. The electronic submission is also accepted if the manuscript is prepared in an editable format (MS Word is preferred). Manuscripts should be submitted to one of editors-in-chief listed in the left side.

2. Preparation of the manuscript

General : The manuscripts should be in English and typed with double line spacing on single side of A4 paper. The first page of an article should contain; (1) a short title (reflecting the content of the paper), (2) all the name(s) and address(es) of author(s), (3) name and address of the author to whom correspondence and proofs should be sent, and (4) an abstract of 100-200 words. The paper should be concluded by proper conclusions which reflect the findings in the paper. The length of paper should not exceed 16 journal pages (approx. 9000-words equivalent). There will be no page charges if the length of paper is within the limit. A separate list of key words should be provided at the end of the manuscript.

Tables and figures : Tables and figures should be consecutively numbered and headed with short titles. They should be referred to in the text as Fig. 1, Table 2, etc. Originally drawn figures and glossy prints of photographs should be provided in a form suitable for photographic reproduction and reduction in the journal. A separate list of captions for illustrations should be provided at the end of the manuscript.

Units and mathematical expressions : It is desirable that units of measurements and abbreviations should follow the Systeme International (SI). The numbers identifying the displayed mathematical expression should be placed in parentheses and referred to in the text as Eq. (1), Eq. (2).

References : References to published literature should be referred in the text by the last name(s) of author(s) and the year of publication of the reference (e.g., Choi and Schnobrich 1975) and listed in the alphabetical order of the last name of the first author in an appendix at the end of the paper. Journal titles should be abbreviated in the style of the World List of Scientific Periodicals. References should be cited in the following style.

Journal: Choi, C.K. and Kim, S.H. (1989), "Coupled use of reduced integration and nonconforming modes in improving quadratic plate element", *Int. J. Num. Meth. Eng.*, **28**(4), 1909-1928.

Book: Salvadori, M.G. and Baron, M.L. (1961), *Numerical Methods in Engineering*, Prentice-Hall, Englewood Cliffs, NJ.

Proceedings: Choi, C.K. and Kwak, H.G. (1989). "Optimum RC member design with discrete sections", *Proceedings of '89 ASCE Structures Congress*, San Francisco, May.

3. Proofs

Proofs will be sent to the corresponding author to correct any typesetting errors. Alterations to the original manuscript at this stage will not be accepted. Proofs should be returned within 48 hours of receipt by Express Mail.

4. Copyright

Submission of an article to "Steel & Composite Structures" implies that it presents the original and unpublished work, and not under consideration for publication elsewhere. On acceptance of a manuscript submitted, the copyright thereof is transferred to the publisher by the Transfer of Copyright Agreement.

5. Reprints

A total of 50 reprints of each paper will be supplied free of charge to the corresponding author.